

AOD, 4R70W, & AODE Transmission Selector Shaft, Flange, & Arm Installation Instructions



AOD, 4R70W, & AODE Transmission Selector Shaft, Flange, & Arm Installation Instructions

Building American Quality... With A Lifetime Warranty!®

TOLL FREE 1-877-469-7440 • tech@lokar.com • www.lokar.com

General Installation Notes:

Please read these instructions completely before beginning the installation. If you have any questions, please call.

Before beginning the installation, disconnect the negative battery cable and use wheel chocks to block the vehicle's wheels.

Make sure the engine, transmission, body and frame are properly grounded. We recommend using anti-seize lubricant on all aluminum threads.

The Ford AOD Selector Shaft, Flange and Arm also requires installation of an aftermarket Kickdown Kit, available separately.

Refer to Fig. 1 and Fig. 2 for the component names.

NOTE: It will be much easier to install this product before the transmission is installed in the vehicle, if possible.

The AOD (non-computer controlled) transmission has a Throttle Valve (T.V.) shaft that passes through the center of the selector shaft. Parts of these instructions and some of the photos will refer to the T.V. shaft, a T.V. lever, and a T.V. spring. **These parts are not present in an AODE or 4R70W transmission.**

Step 1: Put the transmission in Park by rotating the original trans arm clockwise as far as it will go.

Step 2: AOD Only: Remove the nut and T.V. lever from the T.V. shaft in the center of the selector shaft.

AODE and 4R70W Only: Remove the bolt or nut from the center of the selector shaft, and remove the original trans arm. **NOTE:** If the new Clayton Machine Works Selector Shaft Flange fits on your original selector shaft, it is not necessary to replace the selector shaft. If you are not replacing the original selector shaft and are only installing the Clayton Machine Works Selector Shaft Flange and Arm, skip to **Step 13**.

Step 3: Drain the transmission fluid and remove the transmission pan and filter.

Step 4: Remove the 1/8" diameter roll pin that is located just inside the pan rail on the boss that the selector shaft slides through. The pin protrudes about 1/8" beyond the boss. Use a pair of side cutters to grab the roll pin and pry the pin out using the case as your leverage point. **Fig. 3** If the roll pin has been pushed all the way in previously, you can use a small drill bit to grab the inside of the roll pin to pull it out.

Step 5: Remove the roller spring that holds the gear selector plate in each gear position. **Fig. 4**

Step 6: AOD Only: The T.V. spring keeps tension on the T.V. shaft. Make sure you pay attention to how this spring is positioned, in case the spring moves during selector shaft removal and you have to put it back into position. **Fig. 5**.

All: Move the gear selector plate all the way to the rear to put it into low gear. Hold the gear selector plate with a box end wrench or other tool to keep it from rotating, and unscrew the large nut from the end of the selector shaft. On the AOD transmission, the nut will still be retained by the T.V. shaft and will remain in the transmission. **Fig. 6** and **Fig. 7**

Step 7: AODE and 4R70W Only: Remove the Auto Trans Gear Position Sensor from the outside of the transmission case by removing the mounting bolts and sliding it off of the selector shaft.

All: Remove the original selector shaft from the transmission by sliding it out of the bore. The gear selector plate will stay in the transmission, and you may have to tap on it or lightly pry on it to get it separated from the selector shaft.

Step 8: Lubricate the new Selector Shaft and the selector shaft seal in the transmission with a small amount of transmission fluid or transmission assembly grease. On the AOD only, also lubricate the T.V. shaft seal that is inside the new Selector Shaft. **DO NOT** remove the T.V. shaft seal; it is not necessary to remove it for installation of the Selector Shaft.

Slide the new Selector Shaft into the transmission. On AOD models, the T.V. shaft fits inside the Selector Shaft.

Step 9: Align the two flats on the gear selector plate in the transmission with the flats on the new Selector Shaft, and install the Selector Shaft into the gear selector plate. **Fig. 8** The gear selector plate has a pin attached to it that must be positioned in the groove on the piston that protrudes from the valve body. This pin needs to be in the groove before the large nut is tightened. **Fig. 9** Once the pin is in the groove, tighten the nut.

AOD Only: If the T.V. spring slipped out of place, put the spring back into position as shown in **Fig. 5**. Also, verify that the internal T.V. lever is aligned with the T.V. piston. With the external T.V. lever removed, it is possible for the T.V. shaft and internal lever to slide in too far, and the lever can get trapped between the T.V. piston and the valve body. **Fig. 5** and **Fig. 10**

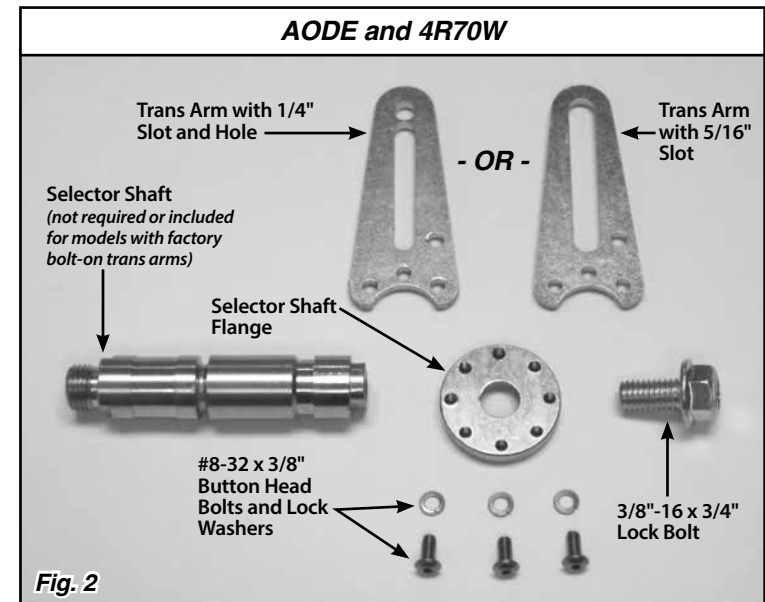
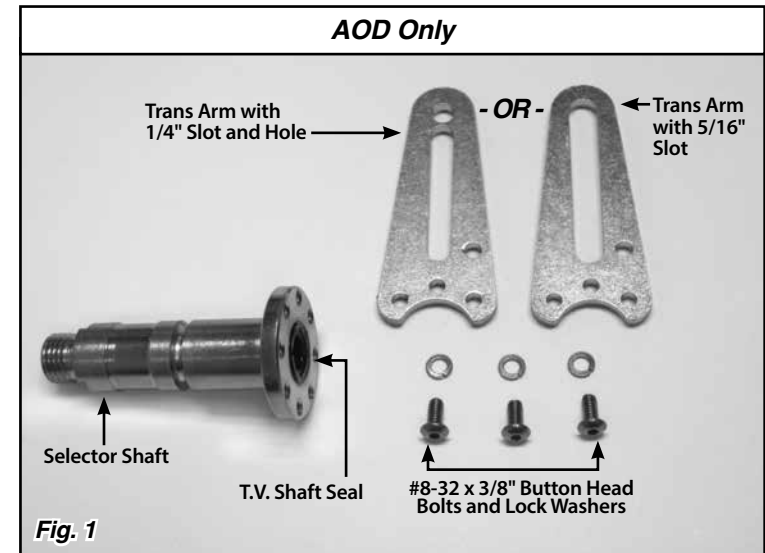

Step 10: Reinstall the roller spring that holds the gear selector plate in gear. **Fig. 11**

Step 11: Reinstall the 1/8" roll pin. It will align with the groove in the Selector Shaft. **DO NOT DRIVE THE ROLL PIN ALL THE WAY IN FLUSH WITH THE CASE!** It is important that the roll pin is sticking out beyond the casting so it can be removed if needed at another time. **Fig. 12**

AODE and 4R70W Only: Reinstall the Auto Trans Gear Position Sensor onto the Selector Shaft and attach to the transmission case using the original bolts. Make sure the tabs on the inside of the sensor are aligned with the slots in the Selector Shaft.

Step 12: Rotate the gear selector plate all the way forward into the "PARK" position.

Step 13: AODE and 4R70W Only: Install the new Clayton Machine Works Flange onto the Selector Shaft. If using the original selector shaft, use the original nut or bolt to retain the Flange. If using the Clayton Machine Works Selector Shaft, install the supplied 3/8"-16 x 3/4" lock bolt into the Selector Shaft to retain the Flange.

All: Install the trans arm onto the new Selector Shaft or Flange using the three #8-32 x 3/8" button head bolts and lock washers. When using a Transmission Mount, Tail Mount, or Floor Mount Shifter with rod-type linkage (not cable operated), the Trans Arm needs to be installed at approximately the 12:00 position with the transmission in "PARK". **Fig. 13** If using an OE column shifter (rod type) or a cable-operated aftermarket Floor Mount Shifter, the Trans Arm needs to be installed at approximately the 7:30 position with the transmission in "PARK". **Fig. 14** The Trans Arm may need to be positioned differently to work with different shifters.

The linkage rod or cable from the shifter will be connected to the 1/4" round hole at the end of the trans arm. The 3/16" diameter hole that is part way up the arm and next to the slot should be towards the back of the transmission. This hole is used with an aftermarket Shift Indicator Kit.

This Selector Shaft will work with a variety of other shifters. The slot gives the ability to adjust the center distance of the shift linkage at the transmission.

Step 14: AOD Only: Verify that the internal T.V. lever is still aligned with the T.V. piston. Install the external T.V. lever, following the instructions that are provided in that kit. This will prevent the internal T.V. lever from becoming misaligned.

All except Flange-and-Arm only installations: Reinstall the filter and the transmission pan. Fill with the appropriate amount of transmission fluid.

Step 15: Double check to make sure all fasteners are tightened properly. Continue with the installation of the shifter mechanism and/or Kickdown Kit.

AOD transmission shown in all of the following photos. AODE and 4R70W are similar.

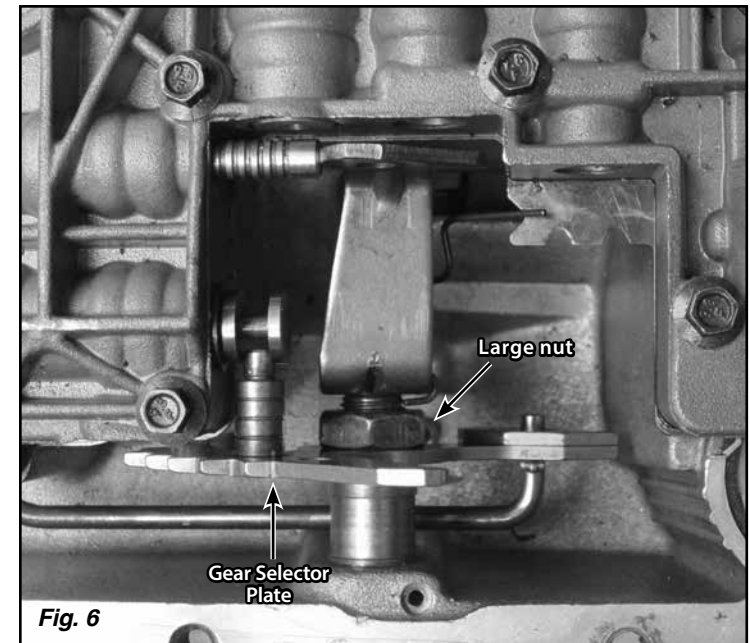
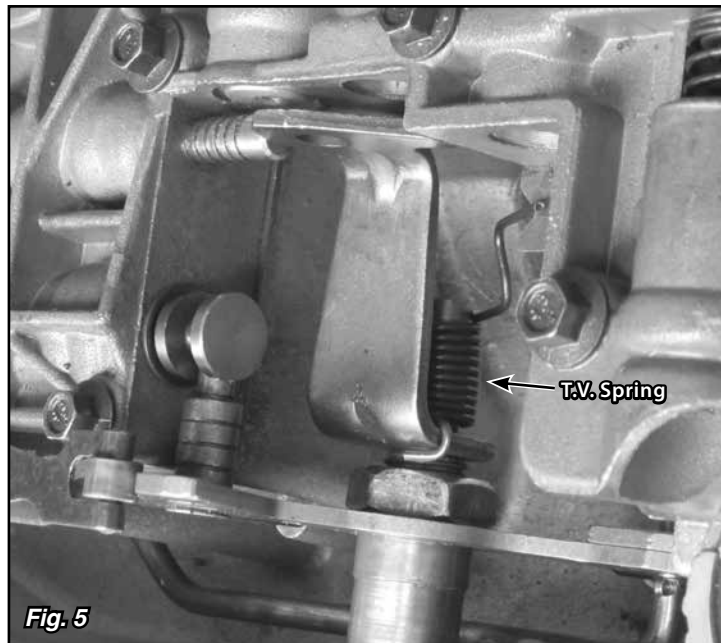
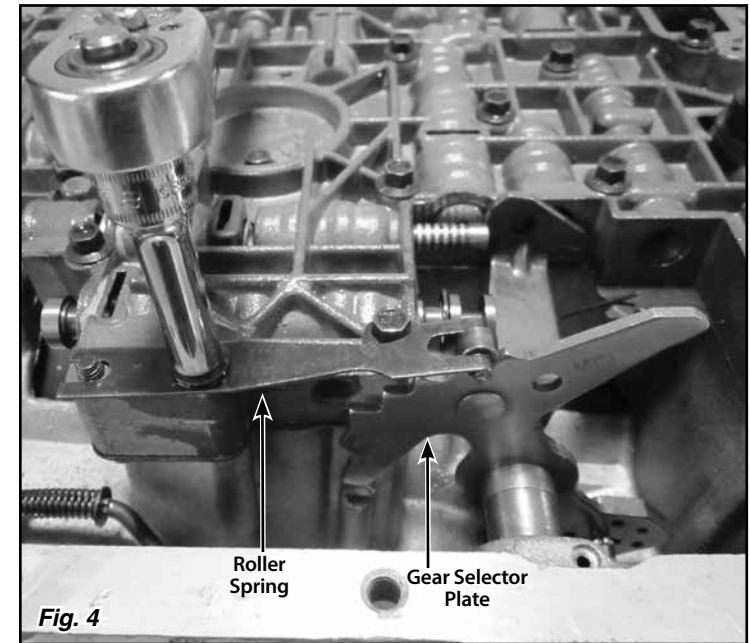
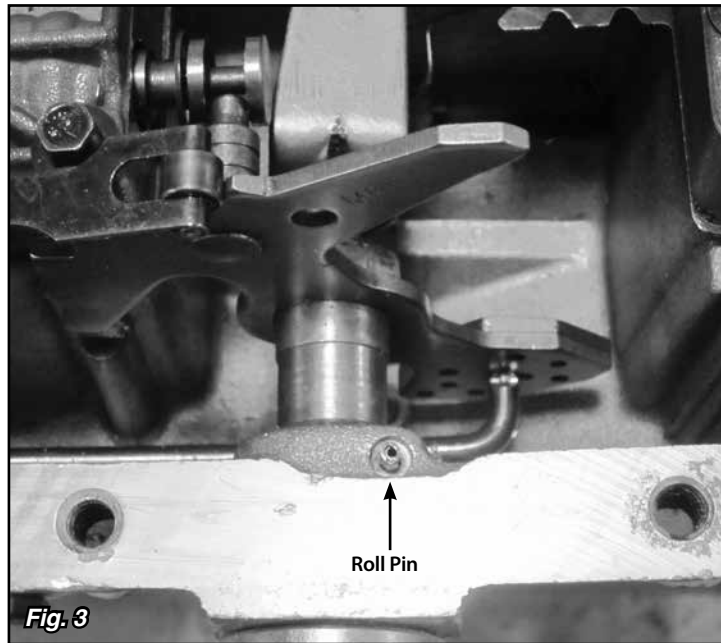

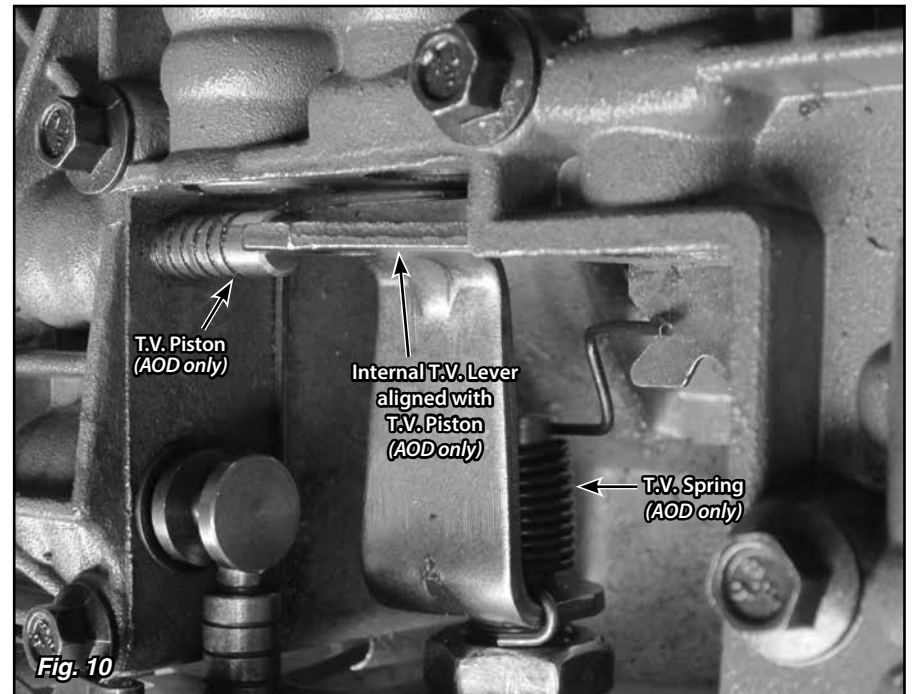
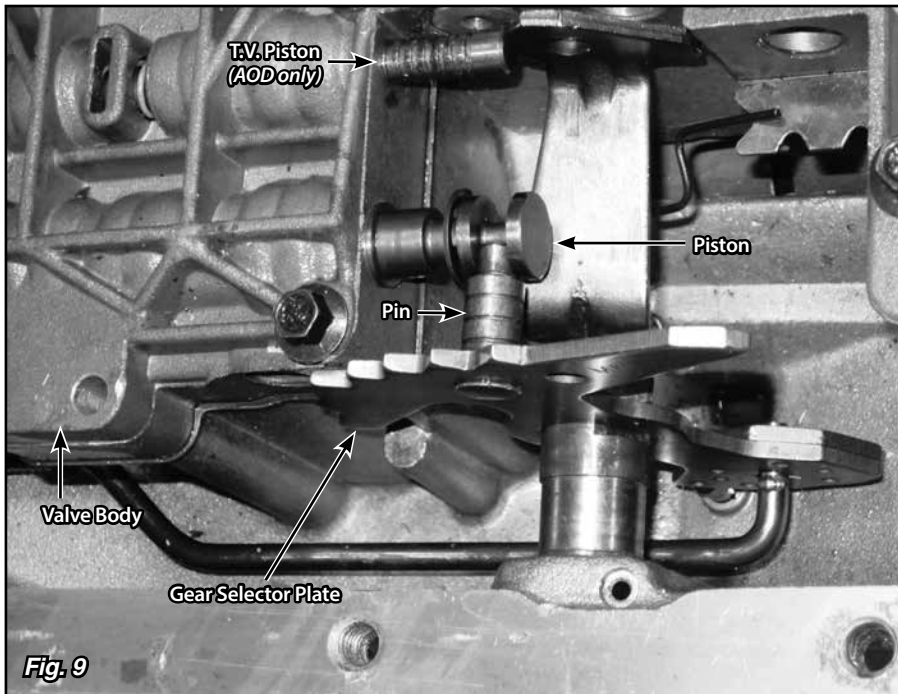
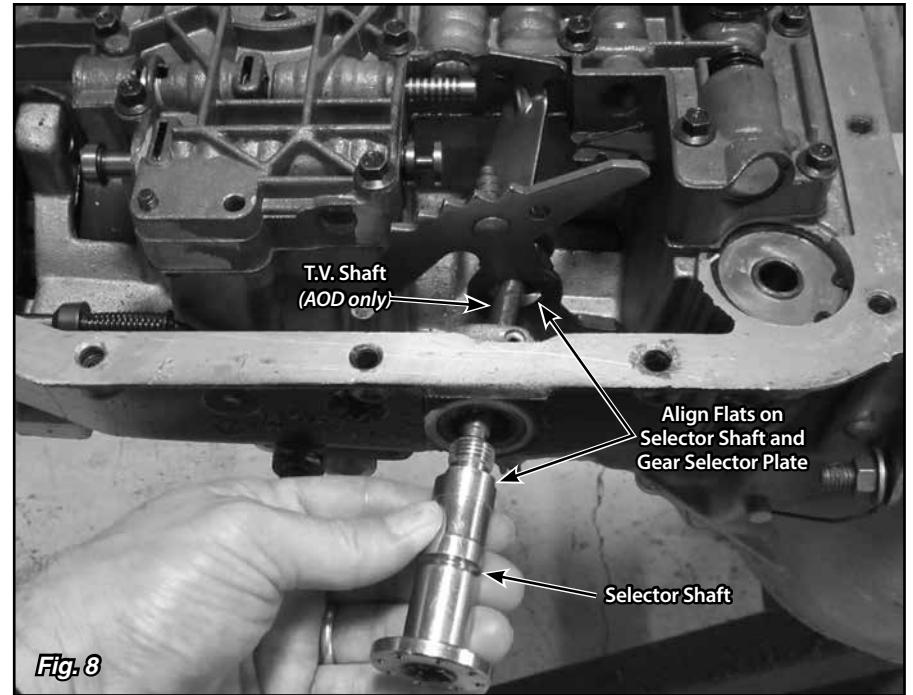
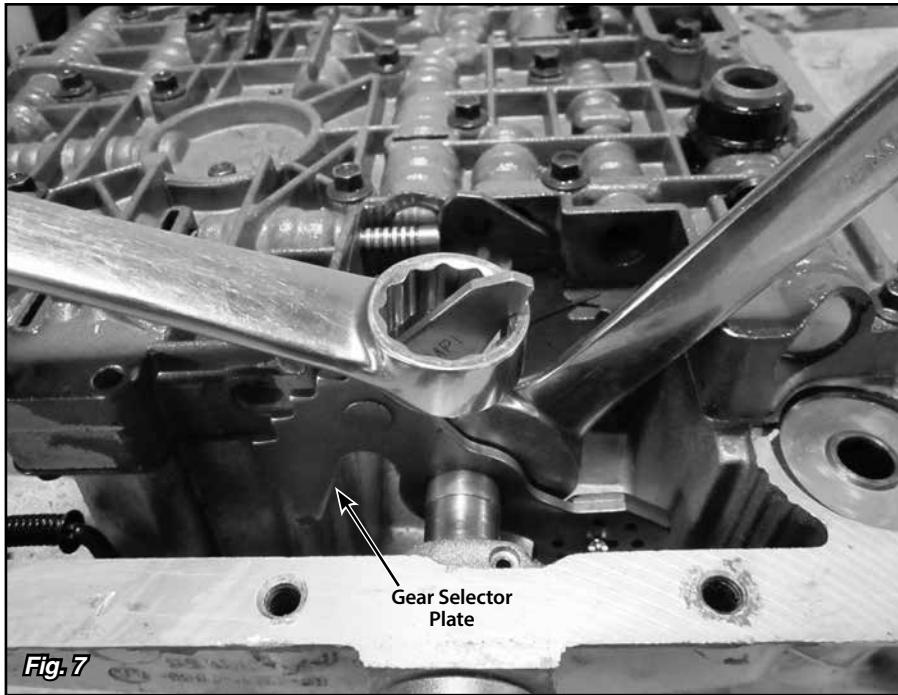

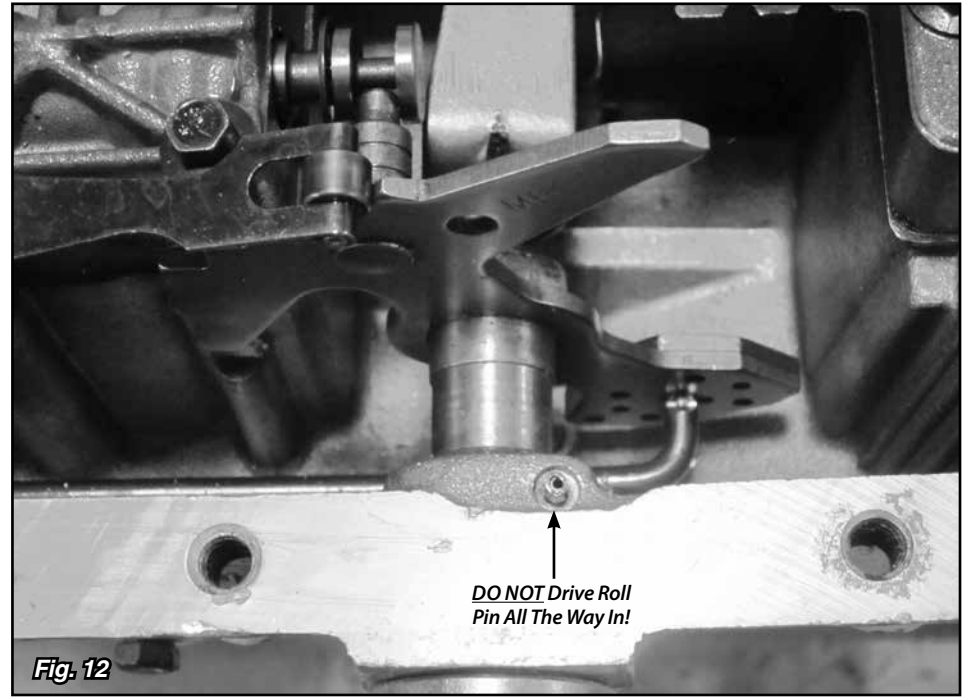
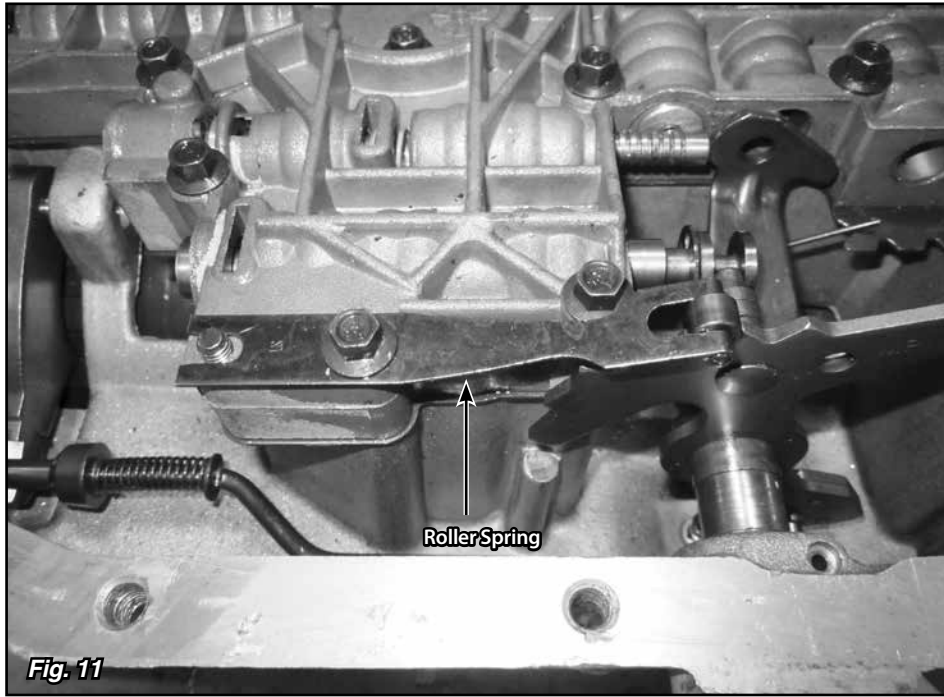

With Transmission Mount, Floor Mount, or Tail Mount Shifters with Solid Rod Type Linkage, Put Trans Arm at 12:00 Position in "PARK"

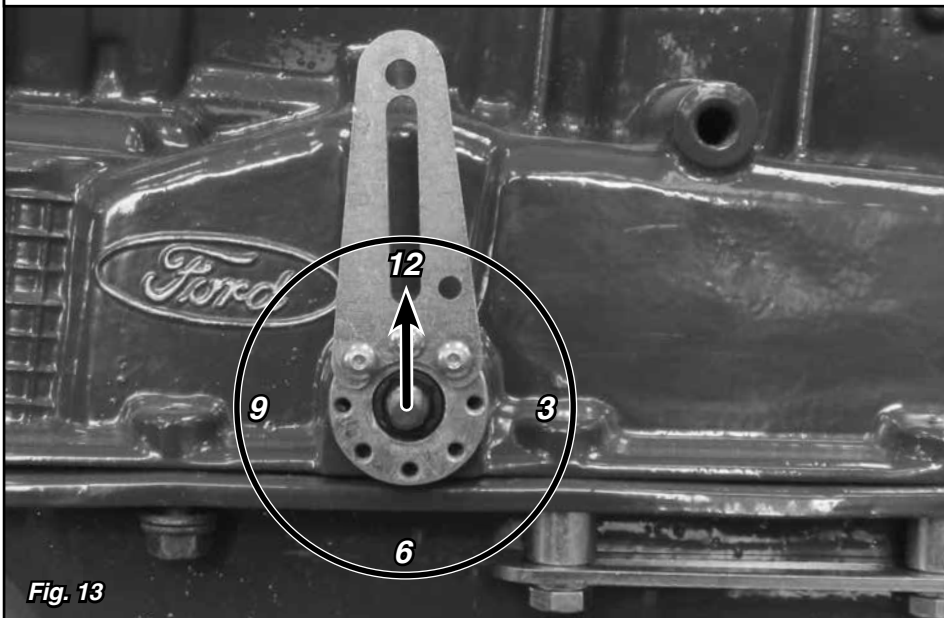

With OE Column (Rod Type) Linkage, or Aftermarket Cable Type Linkage, Put Trans Arm at 7:30 Position in "PARK"

