



QUALITY... PLAIN & SIMPLE®

## Edelbrock Pro-Flo 4 (Late Version) Cable Bracket Installation Instructions

### General Installation Notes:

Please read these instructions completely before beginning the installation. If you have any questions, please call.

Before beginning the installation, disconnect the negative battery cable and use wheel chocks to block the vehicle's wheels.

Make sure the engine, transmission, body and frame are properly grounded. We recommend using anti-seize lubricant on all aluminum threads.

Refer to Fig. 1 and Fig. 2 for the component names.

**This Cable Bracket is designed to work with a Lokar Throttle Cable, a Lokar Kickdown Kit (if applicable), and a Lokar Cruise Control Cable (if applicable).**

We recommend using a shop towel to block the opening under the plenum, to make it easier to retrieve dropped parts.

There are two versions of the Edelbrock Pro-Flo 4 Throttle Body. Early versions have the MAP sensor mounted on the passenger side rear throttle body mounting stud, with a short piece of vacuum hose connected. Late versions have the MAP sensor mounted directly on the front of the throttle body assembly, with no vacuum hose.

**Step 1:** Verify that you are working on a late version of the Pro-Flo 4 Throttle Body, with the MAP sensor mounted directly onto the front of the throttle body. **Fig. 3**

**Step 2:** Apply thread locking compound to the threads on the kickdown pivot stud. Install the kickdown pivot stud and pivot stud nut into the lower hole in the throttle body linkage arm. Tighten using a 1/2" wrench. **Fig. 4**

**Step 3:** Remove the driver side rear throttle body mounting nut, washer, and stud from the intake manifold.

**Step 4:** Attach the return spring to the cable bracket as shown in **Fig. 5**, with the open side of the spring hooks on the bottom. It is important that the spring is attached in the orientation shown.

# Edelbrock Pro-Flo 4 (Late Version) Cable Bracket Installation Instructions

Building American Quality... With A Lifetime Warranty!®

TOLL FREE 1-877-469-7440 • tech@lokar.com • www.lokar.com

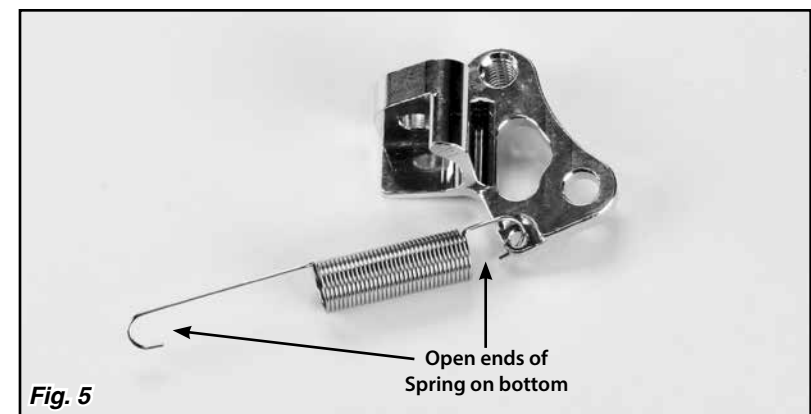
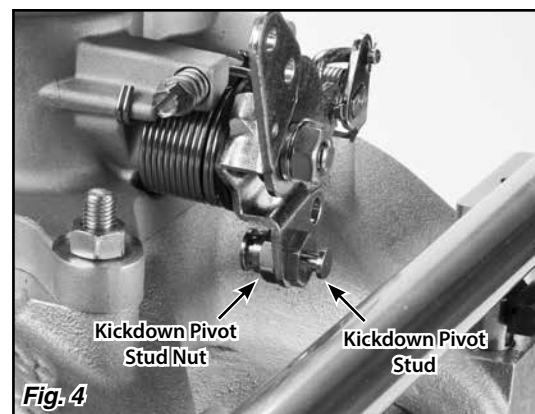
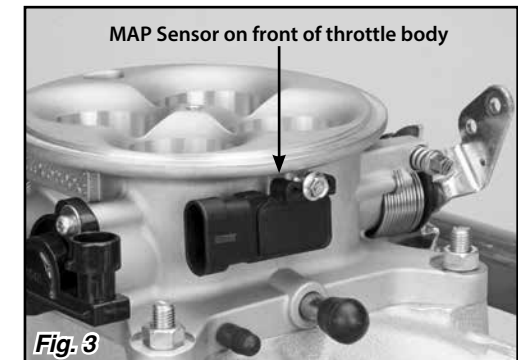
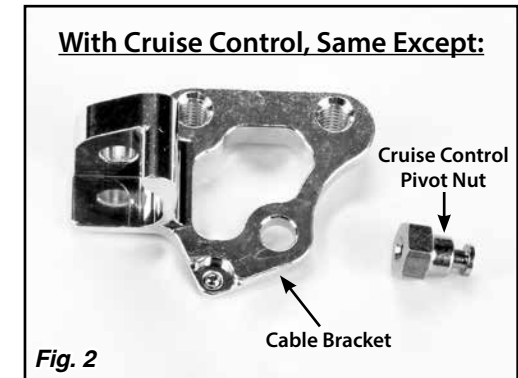
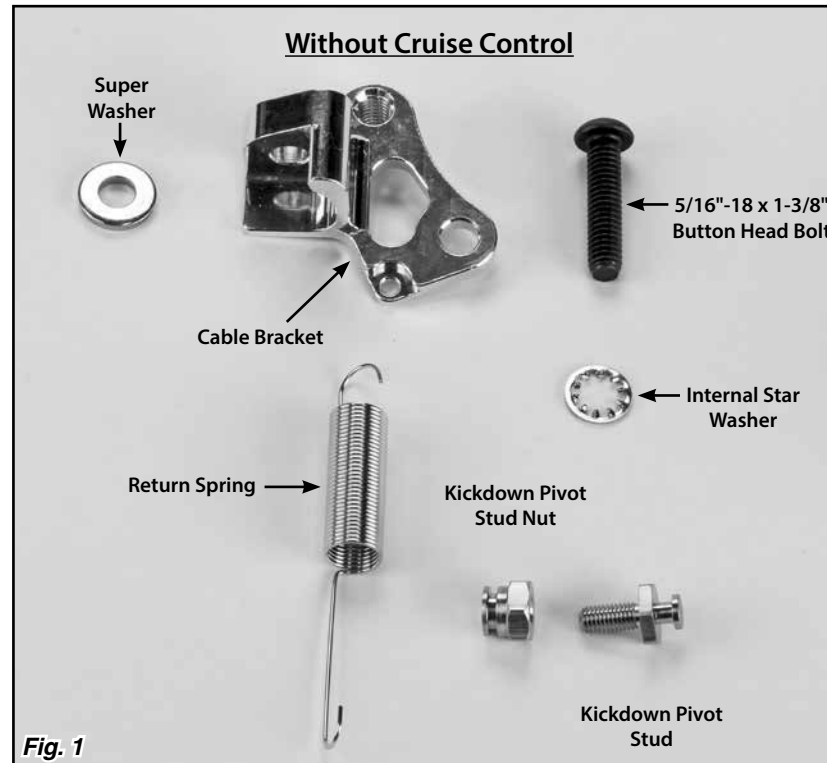

## Edelbrock Pro-Flo 4 (Late Version) Cable Bracket Installation Instructions

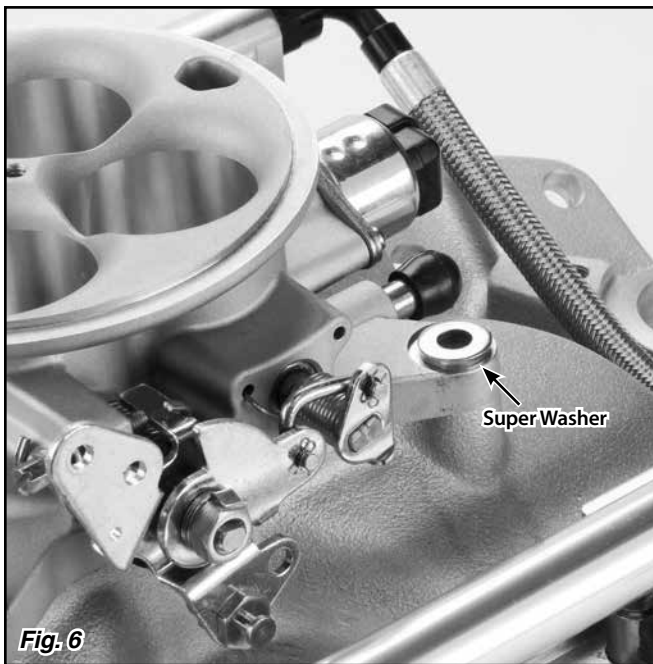

**Fig. 6**

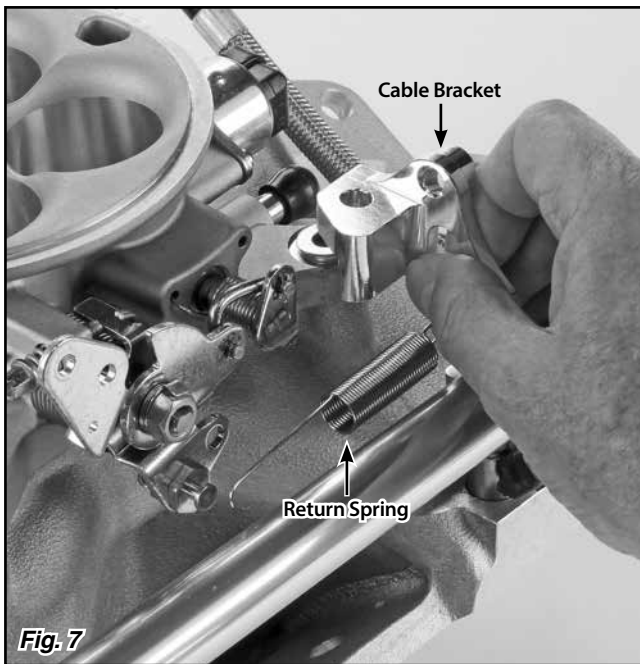

**Fig. 7**

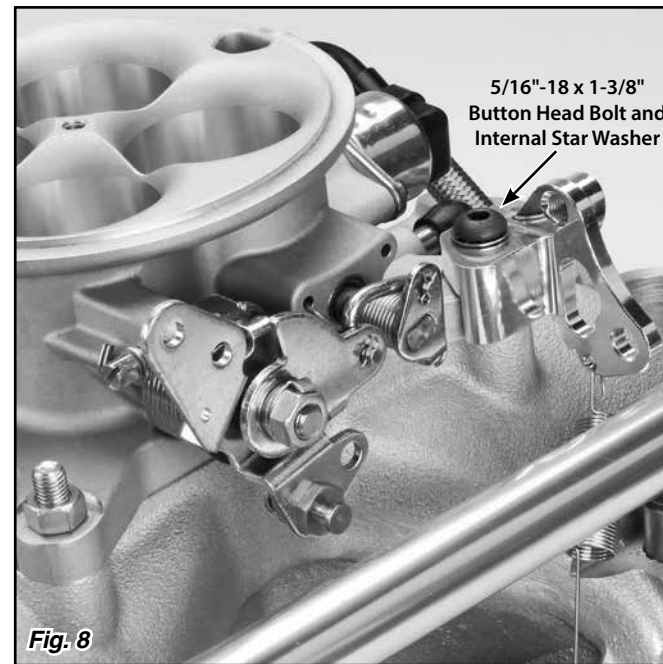

**Fig. 8**

**Step 5:** Place the included super washer on the driver side rear corner of the throttle body so that the mounting bolt will pass through it. **Fig. 6** Position the cable bracket on the super washer as shown in **Fig. 7**, holding the return spring towards the front of the engine. Install the 5/16"-18 x 1-3/8" button head bolt and internal star washer, using a 5/16" Allen wrench or hex bit. As you tighten the bolt, rotate the cable bracket forward (clockwise as viewed from the top) as far as it can go, so that the cable bracket is at a 90 degree angle to the throttle body linkage arm. **Fig. 8**

**NOTE:** If you are not able to rotate the cable bracket fully around to 90 degrees, loosen the other three throttle body mounting nuts. Then, rotate the cable bracket to 90 degrees, tighten that bolt, and tighten the other three corners.

**Step 6:** Pull the long arm of the return spring forward and hook it into the groove on the kickdown pivot stud nut, making sure that the open side of the spring hook is on the bottom. **Fig. 9**

**Step 7:** Install and connect your Cables following the instructions that came with those parts.

**NOTES:** You will only need to use one cable adjuster nut on the Throttle Cable and (if applicable) Cruise Control Cable adjusters, since the Pro-Flo 4 Cable Bracket has threaded holes in those locations.

The carb end assembly on the Throttle Cable must be positioned on the **INSIDE** of the Pro-Flo 4 throttle linkage for alignment purposes. **Fig. 10** If installing a Cruise Control Cable, use the provided cruise control pivot nut to secure the carb end assembly onto the throttle linkage. **Fig. 10**



**Fig. 9**

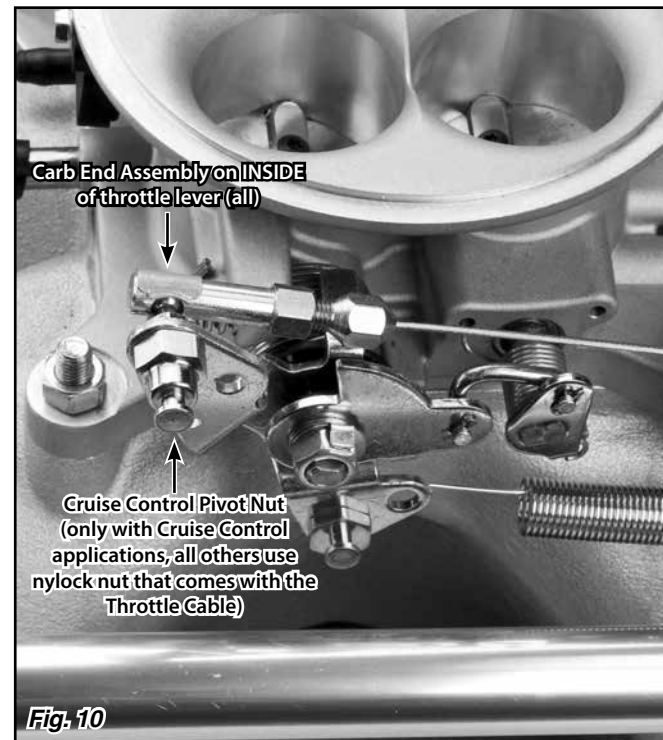

**Fig. 10**