



QUALITY... PLAIN & SIMPLE®

Ford AOD Bell Crank Kit Installation Instructions

Ford AOD Bell Crank Kit Installation Instructions

Building American Quality... With A Lifetime Warranty!®

TOLL FREE 1-877-469-7440 • tech@lokar.com • www.lokar.com

General Installation Notes:

Please read these instructions completely before beginning the installation. If you have any questions please call.

Before beginning the installation, disconnect the negative battery cable and use wheel chocks to block the vehicle's wheels.

Make sure the engine, transmission, body and frame are properly grounded. We recommend using anti-seize lubricant on all aluminum threads.

Refer to Fig. 1 for the component names.

NOTE: This Bell Crank Kit is required when the Lokar Transmount Shifter is installed at the very front of the shifter main plate.

Step 1: Install the Lokar Shifter Kit With Selector Shaft (not included) onto the transmission following the instructions that came with the shifter and the selector shaft, but stop before measuring, cutting, and installing the threaded rod that connects the quad lever on the shifter to the trans arm on the transmission selector shaft.

Step 2: Put the shifter into Park. Remove the original quad lever from the shifter by loosening the 1/4"-20 x 5/16" set screw and sliding the quad lever off of the shifter assembly. Fig. 2

Step 3: Install the new two-piece quad lever assembly onto the shifter, with the quad lever pointed down towards approximately the 5:00 to 5:30 position. Tighten the 1/4"-20 x 5/16" set screw, and tighten the 1/4"-28 x 5/8" button head bolts with nylock nuts that hold the two-piece quad lever assembly together. Fig. 3

Step 4: Rotate the transmission selector shaft clockwise until it is in Park. If you have already installed the trans arm (not included, part of the Lokar Shifter Kit), it will need to be removed and repositioned so that it points to approximately the 1:30 position in Park. If you have not yet installed the trans arm onto the transmission selector shaft, install it so that it points towards approximately the 1:30 position. Fig. 4

Step 5: Remove the upper and middle tailhousing bolts from the left hand side of the transmission. The bell crank mounting bracket must be installed to the rear of the shifter's rear mounting bracket, with the thick 5/16" washer on the middle bolt between the bottom of the bell crank mounting bracket and the transmission tailhousing. Install the bell crank mounting bracket using the upper bolt that came with the Lokar Shifter Kit, and the original tailhousing bolt in the middle of the tailhousing (at the bottom of the bracket). Fig. 5

Step 6: Attach the linkage arm and nylon friction washer to the bell crank mounting bracket as shown in Fig. 6, using the 5/16"-24 x 1" button head bolt, flat washers, and nylock nut. Make sure the nylon friction washer is in between the linkage arm and the mounting bracket. Position the linkage arm at approximately the same angle as the trans arm on the selector shaft (the 1:30 position), and tighten the nylock nut. Fig. 6 and Fig. 7

Step 7: Measure the distance from the center of the 1/4" hole in the linkage arm to the center of the 1/4" hole in the quad lever on the shifter (Fig. 8 distance "A"). Subtract 1-3/4" from your measurement and write it down.

Next, measure the distance from the 1/4" hole in the linkage arm to the 1/4" hole in the trans arm on the selector shaft (Fig. 8 distance "B"). Subtract 1-3/4" from your measurement and write it down.

IMPORTANT: After you have recorded your measurements, loosen the 5/16"-24 nylock nut on the linkage arm just enough so that the linkage arm can swing freely.

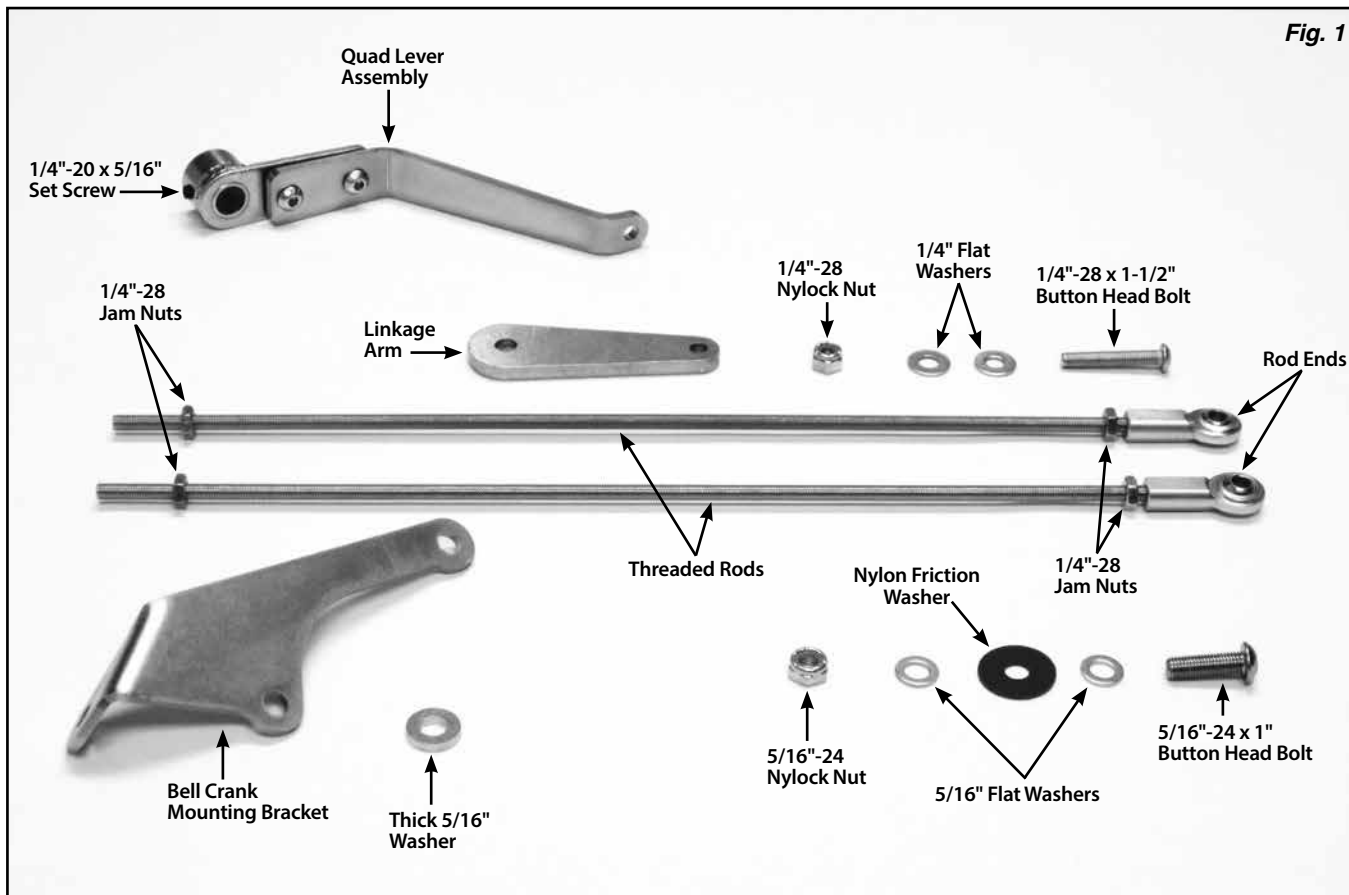

Ford C4 Bell Crank Kit Installation Instructions

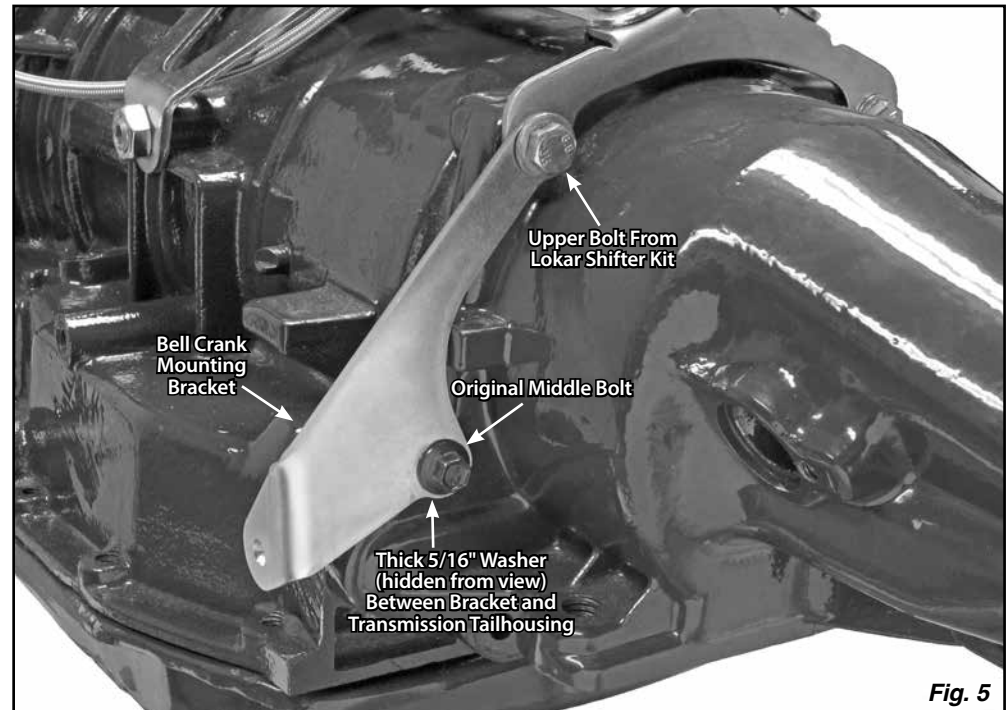
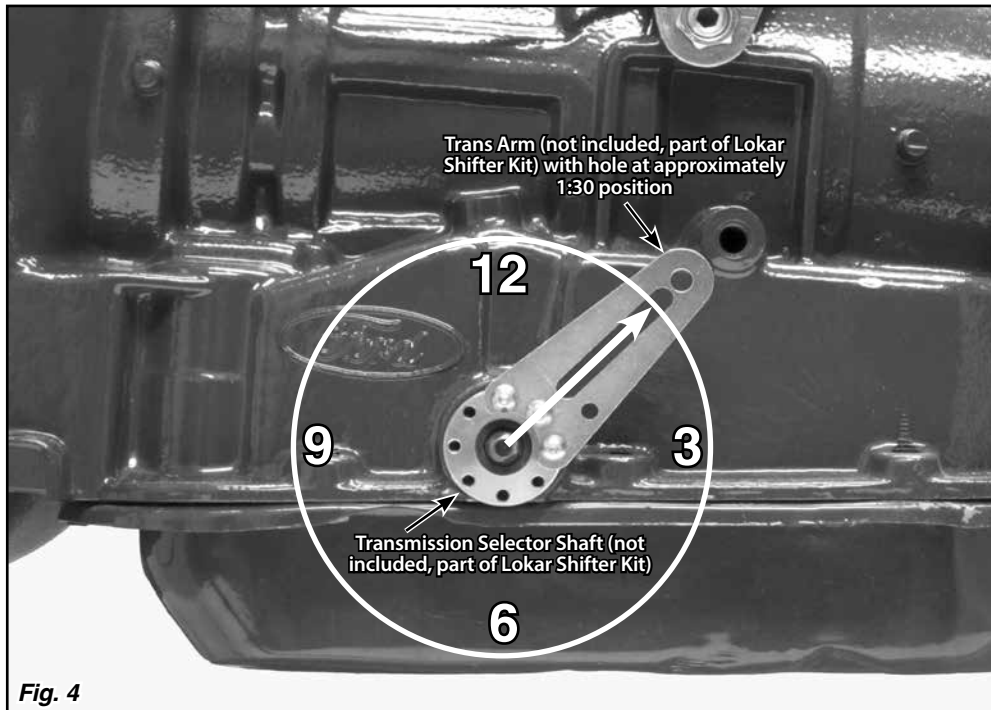
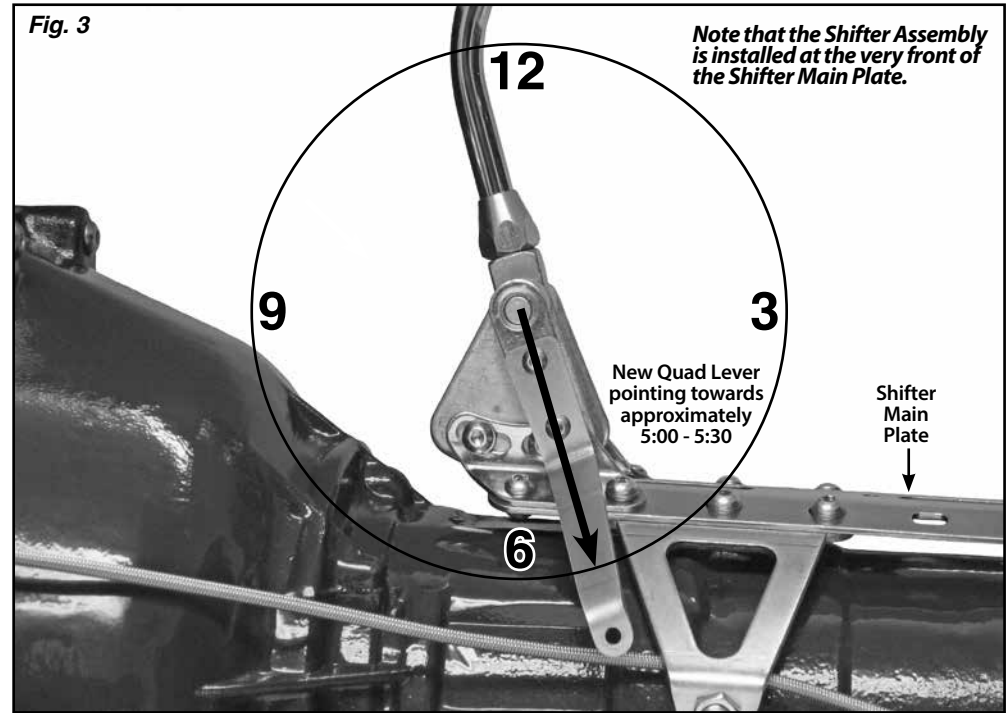
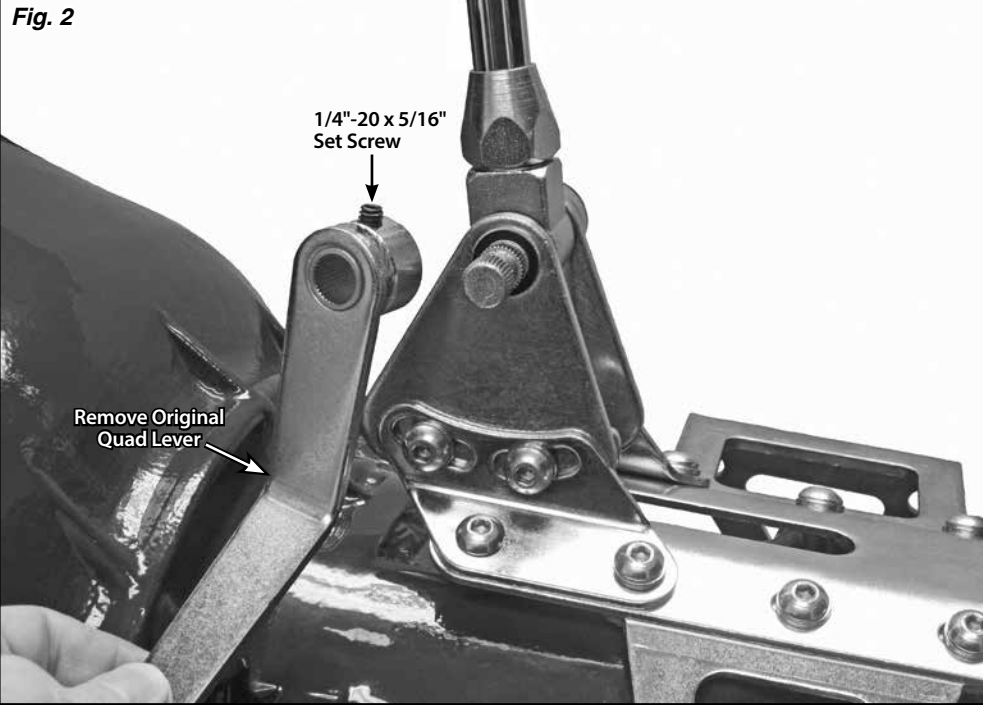

Ford AOD Bell Crank Kit Installation Instructions

Shown with the Mounting Bracket not installed for clarity. The Button Head Bolt may be installed from either direction.

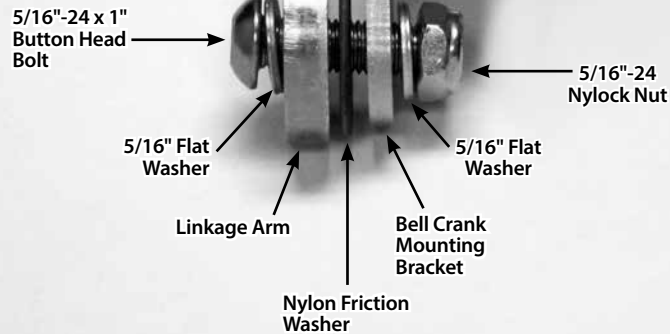

Fig. 6

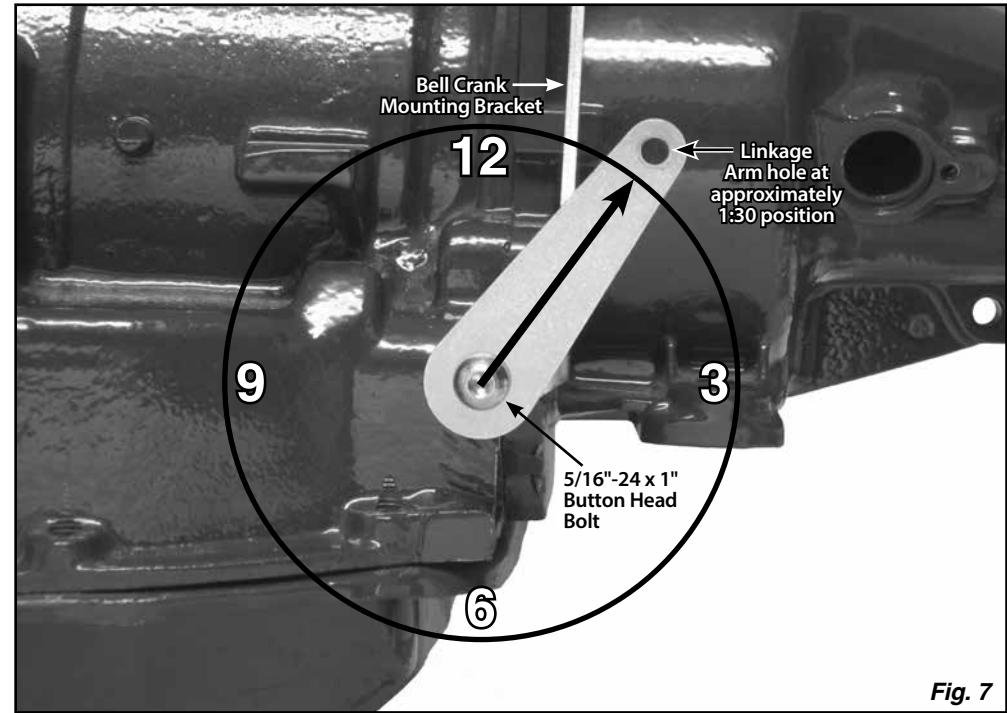

Fig. 7

Step 8: Remove the rod ends from the threaded rods that came with the bell crank kit. Also remove the two rod ends from the threaded rod that originally came with the Lokar shifter.

Mark one threaded rod "A" for the upper rod, and mark the other one "B" for the lower rod. Cut the threaded rods to the lengths you calculated in the previous step and de-burr the cut ends. Make sure two 1/4"-28 jam nuts are on each threaded rod, and install a rod end on both ends of each of the threaded rods (using two rod ends from the Lokar shifter) to create the upper and lower rod assemblies. Each of the rod ends should be threaded on approximately 3/8".

When assembled, the center to center lengths of the upper and lower rod assemblies should match the original "A" and "B" measurements.

Step 9: Install the lower rod assembly (marked "B") onto the inside of the trans arm (towards the transmission) using the 1/4"-28 x 1" button head bolt, flat washer, and nylock nut that came with the Lokar shifter. The bolt can be installed from either direction, but make sure the rod end is sandwiched between the flat washer and the trans arm.

Connect the opposite end of the lower rod assembly to the outside of the linkage arm (away from the transmission) by inserting the supplied 1/4"-28 x 1-1/2" button head bolt with flat washer through the rod end and into the linkage arm (do not install the nylock nut yet). Double check to make sure the linkage arm is at approximately the 1:30 position, and adjust the length of the threaded rod assembly if needed.

Step 10: Make sure the shifter is in Park. Connect the upper rod assembly (marked "A") to the outside of the quad lever on the shifter using the 1/4"-28 x 1" button head bolt, flat washer, and nylock nut that came with the Lokar shifter. Make sure the rod end is sandwiched between the quad lever and the flat washer. The button head bolt (not included, part of the Lokar Shifter Kit) can be installed from either direction.

Step 11: Install the opposite end of the upper rod assembly onto the 1/4"-28 x 1-1/2" button head bolt on the inside of the bell crank linkage arm (towards the transmission), adjusting the length of the upper rod assembly as needed. Install a flat washer and 1/4"-28 nylock nut onto the bolt. **Fig. 9** and **Fig. 10**

Step 12: With the shifter still in Park, check to make sure that there isn't any slack in the linkage, and that the linkage is not under tension. Make sure that the button in the shift knob moves up and down freely. Tighten the 1/4" jam nuts on the threaded rods.

For final adjustments and to complete the shifter installation, return to the Lokar Shifter Installation Instructions.

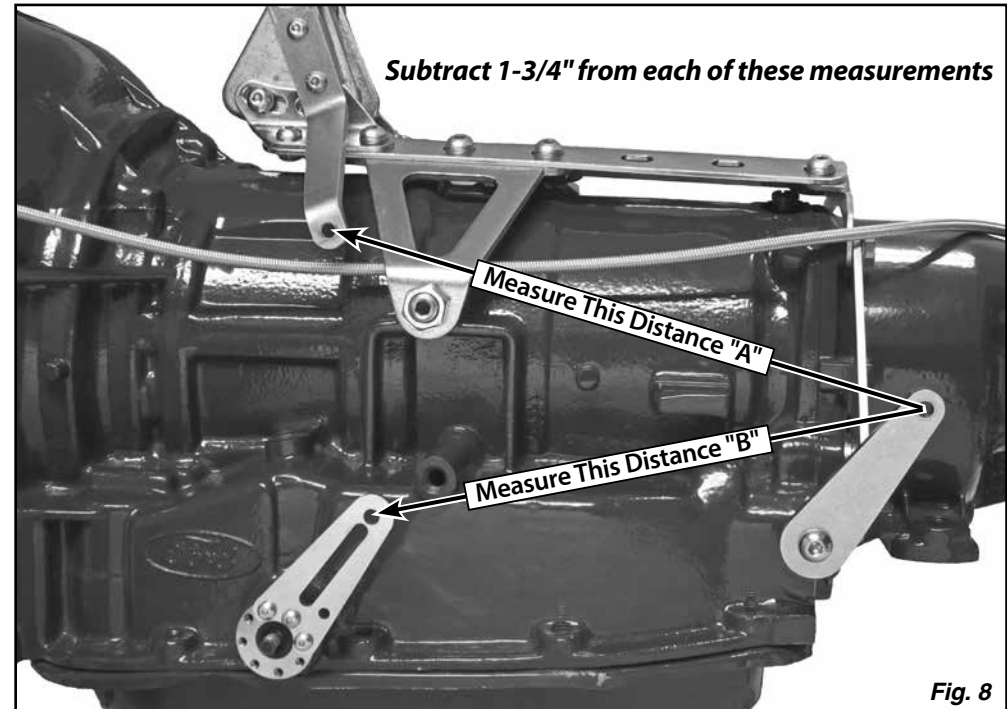

Fig. 8

Ford AOD Bell Crank Kit Installation Instructions

