



QUALITY... PLAIN & SIMPLE®

**Tri-Power Throttle Cable Bracket with Springs
Installation Instructions for Rochester 4-Bolt Carburetors**

General Installation Notes:

Please read these instructions completely before beginning the installation. If you have any questions please call.

Before beginning the installation, disconnect the negative battery cable and use wheel chocks to block the vehicle's wheels.

Make sure the engine, transmission, body and frame are properly grounded.

The Lokar Tri-Power Bracket and Spring Kit is designed to be installed with a Lokar Throttle Cable, and a Lokar Kickdown Kit (if applicable), both available separately. These instructions are for both the small base Rochester carburetors and the Pontiac (large base) Rochester carburetors.

Items required for installation, not supplied:

- (2) carburetor base gaskets
- (1) 1/4" bolt and nylock nut, if you are not installing a Lokar Kickdown Kit

Refer to Fig. 1 and Fig. 2 for the component names.

Step 1: Remove the rear carburetor from the intake manifold. Clean the carburetor mounting surface on both the intake manifold and the carburetor, and place a new carburetor gasket (not included) onto the intake manifold.

Step 2: Place the Lokar Throttle Cable Bracket on top of the new carburetor gasket, with the tabs on the left. Place another new carburetor gasket (not included) on top of the Throttle Cable Bracket. **Fig. 3**

Step 3: Reinstall the rear carburetor. Install the tear drop onto the bottom hole of the center carburetor throttle arm. If you are not using a Kickdown Kit, you may attach the tear drop using a 1/4" bolt (not included). If you are using a Kickdown Kit, attach the tear drop using the hex carb stud that comes with the Lokar Kickdown Kit.

Secure the tear drop using a nylock nut (not included). Snug the nut down, and then back it off just enough so that the tear drop can rotate freely.

Step 4: Install the throttle return springs. They will connect to the tear drop on the center carburetor throttle arm and to the lower tab on the Lokar Throttle Cable Bracket. Make sure the longer hooks on the springs are connected to the tear drop, as shown in **Fig. 4**. Rotate the throttle to wide open and make sure the springs do not come in contact with the intake manifold or any other parts at any time.

Tri-Power Throttle Cable Bracket with Springs Installation Instructions for Rochester 4-Bolt Carburetors

Building American Quality... With A Lifetime Warranty!®

TOLL FREE 1-877-469-7440 • tech@lokar.com • www.lokar.com

NOTE: (Step 4 Continued) On Pontiac Tri-Power units there is a linkage rod that runs from the front carburetor to the rear carburetor on the right hand side of the intake manifold. This rod may need to be lengthened slightly. The linkage rod has a V-shaped bend in it, and the front carburetor has a small slot in the linkage where this rod attaches. The rod needs to be centered in the carburetor linkage so that it is not touching the front or the rear of the slot. This will ensure that the linkage rod is not pulling the front carburetor open at idle. To lengthen the linkage rod just straighten the V-shaped portion as needed.

Step 5: Proceed with the Throttle Cable and/or Kickdown Kit installation, following the instructions that came with those products. The Throttle Cable will be installed into the larger of the two holes in the upper tab of the Lokar Throttle Cable Bracket. The smaller hole on the upper tab is for attaching a kickdown mounting bracket if needed.

Note that the Throttle Cable is attached to the small hole in the carburetor throttle arm, not the large hole with the bushings. See **Fig. 4** for a completed installation with no Kickdown Kit, and **Fig. 5** for a completed installation with a Lokar Kickdown Kit.

Small Base Throttle Cable Bracket

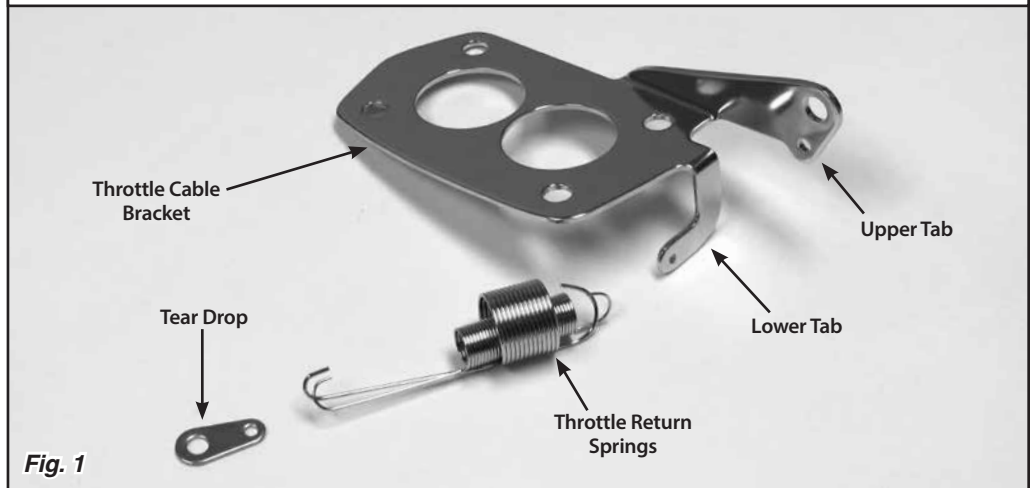

Pontiac (Large Base) Throttle Cable Bracket

