



QUALITY... PLAIN & SIMPLE®

## Connector Cable Installation Instructions for Under-the-Dash Hand Operated or Foot Operated Emergency Brake

### General Installation Notes:

Please read these instructions completely before beginning the installation. If you have any questions, please call.

Before beginning the installation, disconnect the negative battery cable and use wheel chocks to block the vehicle's wheels.

Make sure the engine, transmission, body and frame are properly grounded. We recommend using anti-seize lubricant on all aluminum threads.

Refer to Fig. 1 and Fig. 2 for the component names.

**This Lokar Connector Cable is designed to be used with a Lokar Under-the-Dash Hand Operated or Foot Operated Emergency Brake, and Lokar's Universal Emergency Brake Cables.**

**Step 1:** Remove the inner wire from the cable housing on the new Lokar Connector Cable. **DO NOT remove the ferrule if your cable housing is braided stainless steel!**

**Step 2:** Remove the E-clip from the end of the cable housing. Insert the cable housing into the hand or foot brake mechanism under the dash, and secure the cable housing with the E-clip as shown in Fig. 3 (Hand Brake) or Fig. 4 (Foot Brake).

**Step 3:** Route the cable housing back to the rear Emergency Brake Cables.

**Step 4:** Determine where the single cable adjuster bracket will be mounted. The single cable adjuster bracket must be aligned with the double cable adjuster bracket (not included, comes with the rear Emergency Brake Cables) so that the cables are being pulled in a straight line, not at an angle. If you are using Lokar's Universal Emergency Brake Cables on your rear brakes, the single cable adjuster bracket should be mounted approximately 9-1/2" in front of the double cable adjuster bracket as shown in Fig. 5.

**Step 5:** Mount the single cable adjuster bracket to the underside of the vehicle.

**Step 6:** It will be necessary to shorten the new connector cable housing. **Make sure that the inner wire is removed from the cable housing!** Mark the cable housing where it lines up with the cable adjuster. If the cable housing is braided stainless steel, slide the ferrule up the housing towards the dash, away from the end that is being cut. **DO NOT remove the ferrule if the cable housing is braided stainless steel!** Fig. 6

If the cable housing is black universal, remove the ferrule.

# Connector Cable Installation Instructions for Under-the-Dash Hand Operated or Foot Operated Emergency Brake

Building American Quality... With A Lifetime Warranty!®

TOLL FREE 1-877-469-7440 • tech@lokar.com • www.lokar.com

**Step 6: (Continued)** If the Connector Cable has a braided stainless steel housing, wrap tape around the area to be cut and use a cutoff wheel or fine-toothed hacksaw to cut the cable housing at your mark. If the Connector Cable has the black universal housing, cut the cable housing at your mark using heavy duty 8" diagonal cutting pliers or a hacksaw. Lokar recommends Klein brand Diagonal Cutting Pliers, # D2000-28 available at The Home Depot or through W. W. Graingers, Part # 4A838.

After cutting the cable housing, put the ferrule back in place at the end of the cable housing. The ferrule does **NOT** need to be crimped or otherwise attached in place.

**Step 7:** Insert the cable housing and ferrule into the cable adjuster at the single cable adjuster bracket.

**Step 8: Foot Brake Only:** Install the inner wire into the cable housing, starting from under the dash. Make sure the Foot Brake is in the fully "OFF" position. Insert the cable ball into the slot in the clevis on the hand or foot brake mechanism under the dash.

**Step 8: Hand Brake Only:** Install the clevis supplied with the Hand Brake onto the inner wire. Make sure the Hand Brake is in the fully "OFF" position.

Connect the clevis to the hand brake handle using the clevis pin, flat washer, and cotter pin that are supplied with the Hand Brake. Then, route the inner wire over the pulley in the hand brake assembly and into the cable housing.

**Step 9:** When the inner wire is fully installed, you should have at least a foot or more of the inner wire sticking out of the cable adjuster.

Thread the single wire union assembly approximately 1/2" into the cable union block (not included, comes with the rear Emergency Brake Cables).

**Step 10:** Bring the inner wire up next to the single wire union assembly, and mark the inner wire where it lines up with the tapered end of the single wire union assembly.

**Step 11:** Measure 1-3/8" further towards the rear end of the inner wire and make a second mark. Cut the inner wire at the second mark, so that approximately 1-3/8" of the inner wire can be inserted into the single wire union assembly. Fig. 7

**Step 12:** Loosen the set screws in the single wire union assembly using a 1/8" Allen wrench. Insert the end of the inner wire fully into the single wire union assembly, and tighten the set screws.

**Step 13:** Adjust all cables as necessary to remove any slack.

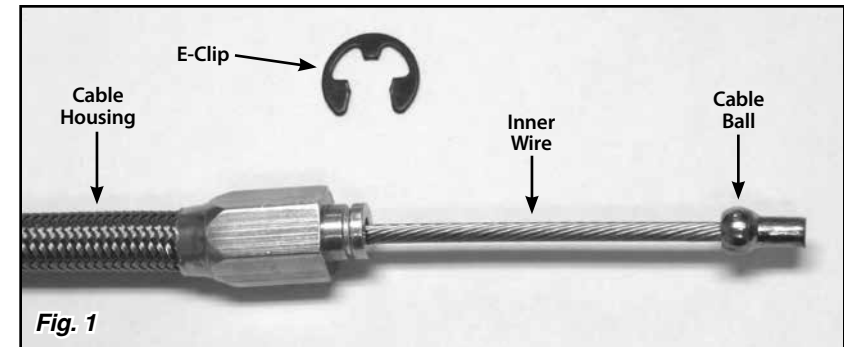

Fig. 1

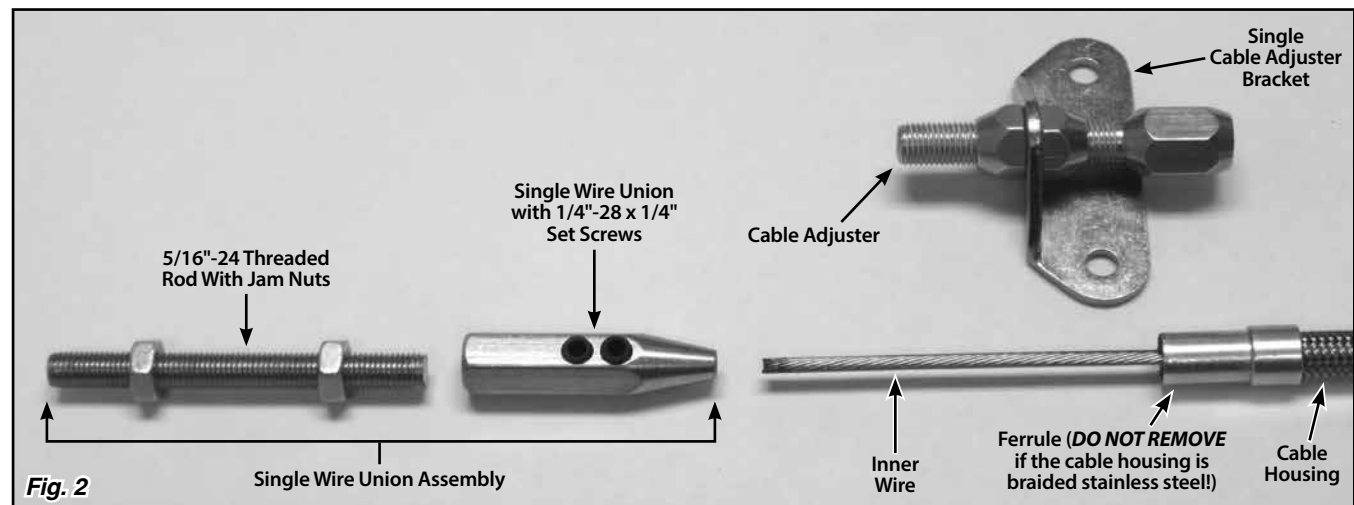

Fig. 2

# Connector Cable Installation Instructions for Under-the-Dash Hand Operated or Foot Operated Emergency Brake

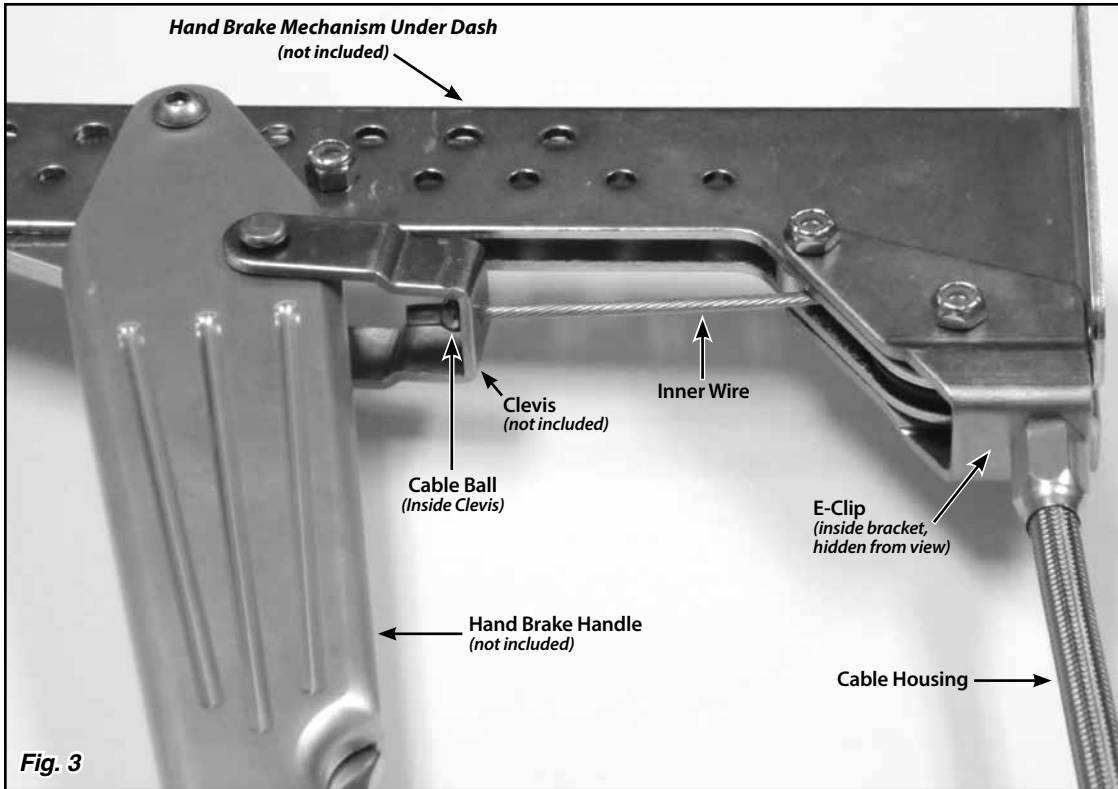

Fig. 3

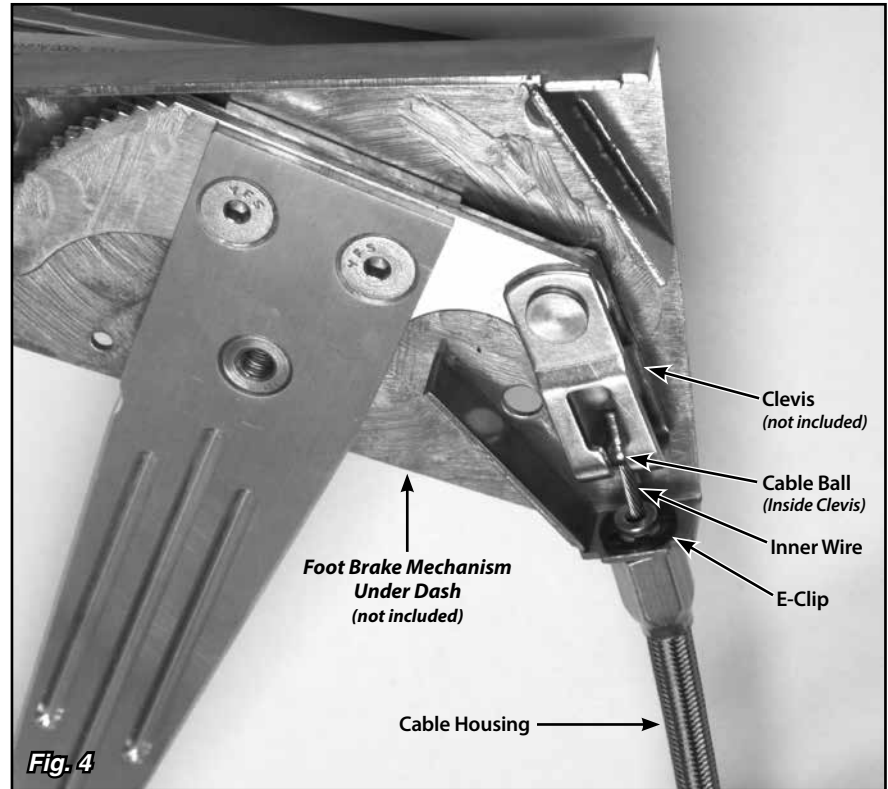

Fig. 4

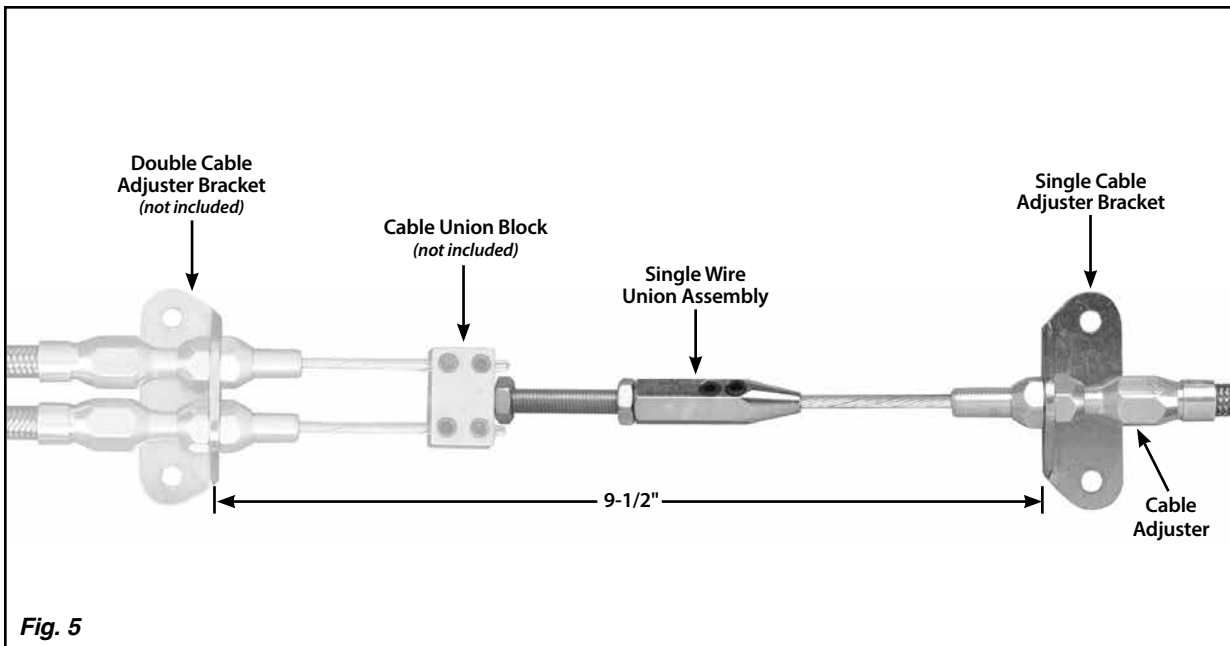

Fig. 5

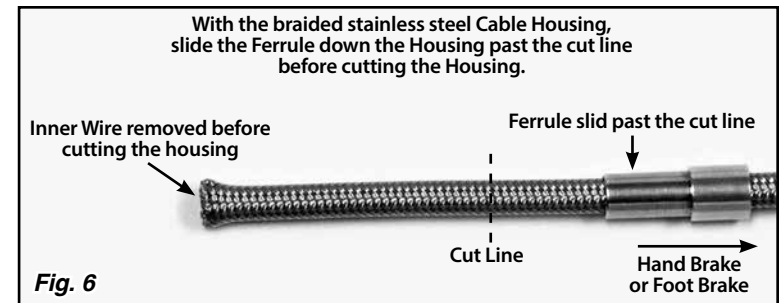

Fig. 6

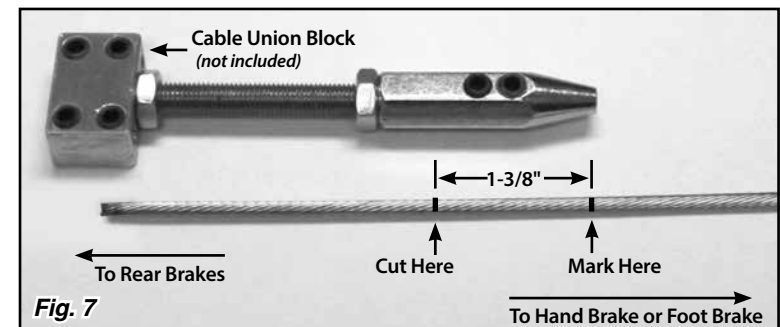

Fig. 7