



**QUALITY... PLAIN & SIMPLE®**

**Adjustable Trans Shift Arm Installation Instructions,  
for Ford C4 & C6**

# Adjustable Trans Shift Arm Installation Instructions, for Ford C4 & C6

**Building American Quality... With A Lifetime Warranty!®**

10924 Murdock Dr. • Knoxville, TN 37932

TOLL FREE 1-877-469-7440 • (865) 966-2269 • FAX (865) 671-1999 • tech@lokar.com • www.lokar.com

**General Installation Notes:**

Please read instructions completely before beginning installation. If you have any questions, please do not hesitate to call.

Before starting installation, set parking brake and scotch vehicle wheels to avoid accidental movement of the vehicle. Disconnect battery cable before starting installation.

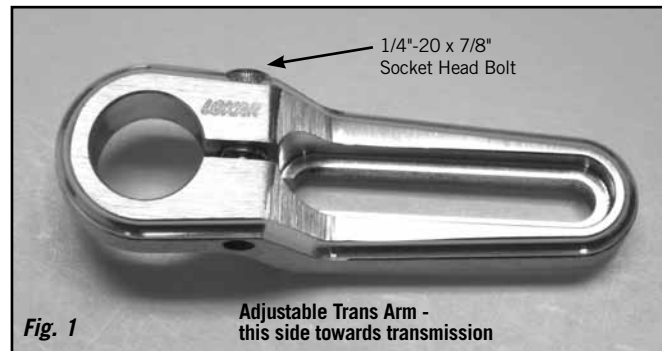

**Step 1:** Put shifter and trans selector shaft into the Park position. Remove original lever from trans selector shaft.

**Step 2:** Install the adjustable trans shift arm onto the trans selector shaft with the "LOKAR" logo facing the transmission. See **Fig. 1** and **Fig. 2**. The positioning varies per application. Adjust the position as needed in order to get the transmission into all gears. Once you get the adjustable trans shift arm positioned properly, tighten the 1/4"-20 x 7/8" socket head bolt to clamp the adjustable trans shift arm to the trans selector shaft.

On some transmissions, the original trans shift arm is welded to the trans selector shaft. If that is the case on your transmission, you may be able to leave the original trans shift arm in place and install the adjustable trans shift arm on the very end of the trans selector shaft. On some transmissions, the original trans shift arm interferes and will need to be cut off in order to install the new adjustable trans shift arm.

The adjustable trans shift arm is designed to use a 5/16" diameter bolt with a 1/2" hex head to connect to the shift linkage (not included). The 1/2" hex head will fit into the slot on the transmission side of the adjustable trans arm, to keep the bolt from spinning when it is tightened. **Fig. 3** Positioning of the shift linkage bolt into the adjustable trans arm slot will depend on the distance between gear positions in the shifter.

