



QUALITY... PLAIN & SIMPLE®

## Lokar Anchor-Tight® Headlight Braid Installation Instructions

### General Installation Notes:

Please read these instructions completely before beginning the installation. If you have any questions please call.

Before beginning the installation, disconnect the negative battery cable and use wheel chocks to block the vehicle's wheels.

Make sure the engine, transmission, body and frame are properly grounded. We recommend using anti-seize lubricant on all aluminum threads.

### Refer to Figs. 1, 2, and 3 for the component names.

Included in each Lokar Anchor-Tight Headlight Braid are four (4) wires. Three (3) of the wires are for a standard headlight connection (refer to your headlight instructions). The fourth wire is intended for a turn signal assembly if needed. This wire may be removed if you wish.

The braided housing is designed to be cut-to-fit. These instructions are for shortening the housing from the grill shell end.

**Step 1:** Remove the wires from the braided housing. Unscrew the grill shell stud from the grill shell end fitting using a 1/4" Allen wrench. You can insert a punch into the hole in the side of the grill shell fitting to aid in holding the fitting still and/or turning the fitting.

**Step 2:** Slide or twist the grill shell end fitting back toward the center of the braided housing.

**DO NOT** remove the grill shell end fitting or headlight end fittings from the braided housing!

**Step 3:** **Make sure the wires have been removed from the braided housing.** Wrap tape around the area to be cut and use an abrasive cutoff wheel or fine-toothed hacksaw to cut the housing to the length you want. You also may use heavy duty 8" diagonal cutting pliers. Lokar recommends Klein brand Diagonal Cutting Pliers, # D2000-28 available at The Home Depot or through W. W. Graingers, Part # 4A838.

**Step 4:** Move the grill shell end fitting back to the end of the housing you just cut. Position the fitting so that the end of the braided housing is approximately 1/2" from the end of the grill shell end fitting. **Fig. 3**

# Lokar Anchor-Tight® Headlight Braid Installation Instructions

Building American Quality... With A Lifetime Warranty!®

TOLL FREE 1-877-469-7440 • tech@lokar.com • www.lokar.com

**Step 5:** Insert a punch into the hole on the side of the grill shell end fitting to keep it from turning, and screw in the 1/2"-20 x 1-5/8" grill shell stud until it is snug. The stud does not have to be very tight to lock the braided housing into the fitting.

**Step 6:** The grill shell end fitting is designed to fit into a 29/32" hole in the grill shell. Install the grill shell end fitting onto the vehicle, with the aluminum cup washer and the 1/2"-20 jam nut on the inside of the grill shell. **Fig. 3**

**Step 7:** Reinstall the wires into the braided housing. Remove the original headlight mounting stud. Install the headlight fitting and 1/2"-20 jam nut as shown in **Fig. 4**.

**Step 8:** Connect the headlight wiring following the instructions that came with your headlight system. See **Fig. 5** for a completed installation. Reconnect the negative battery cable and check operation.

Fig. 1

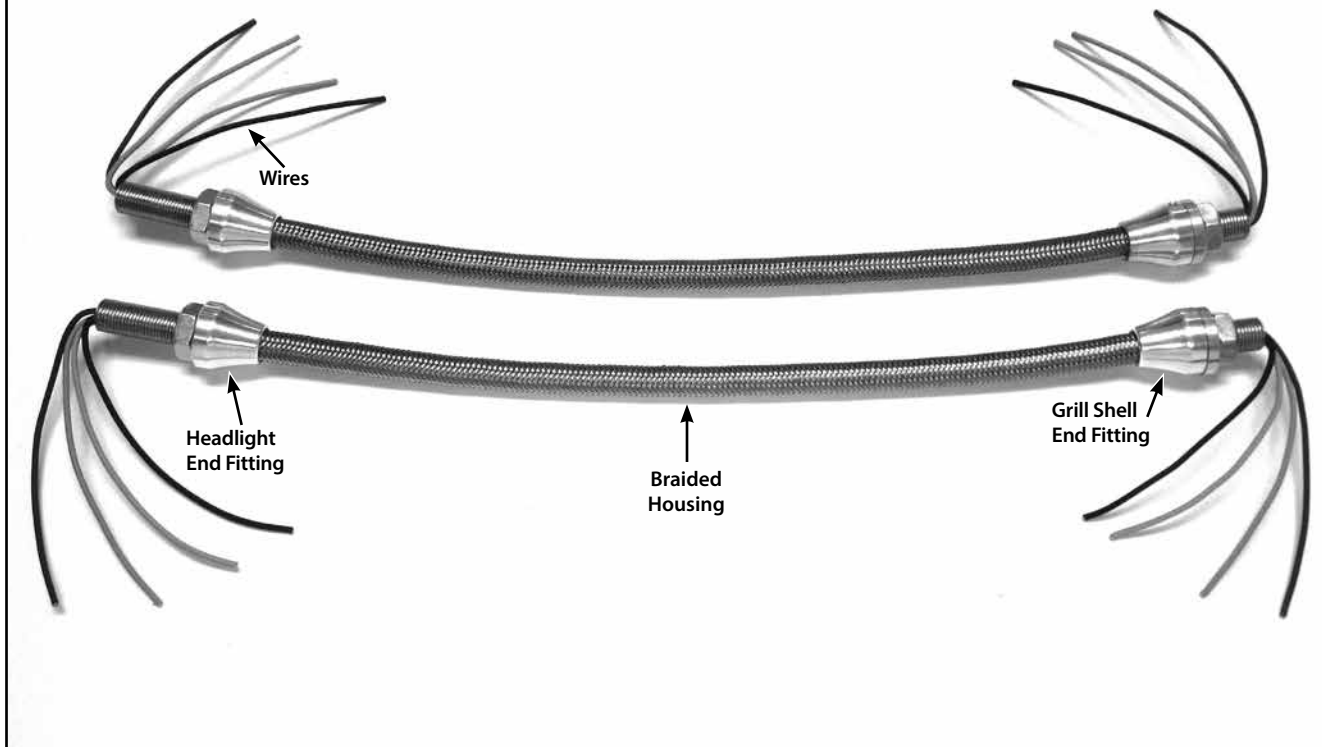

# Lokar Anchor-Tight® Headlight Braid Installation Instructions

Fig. 2

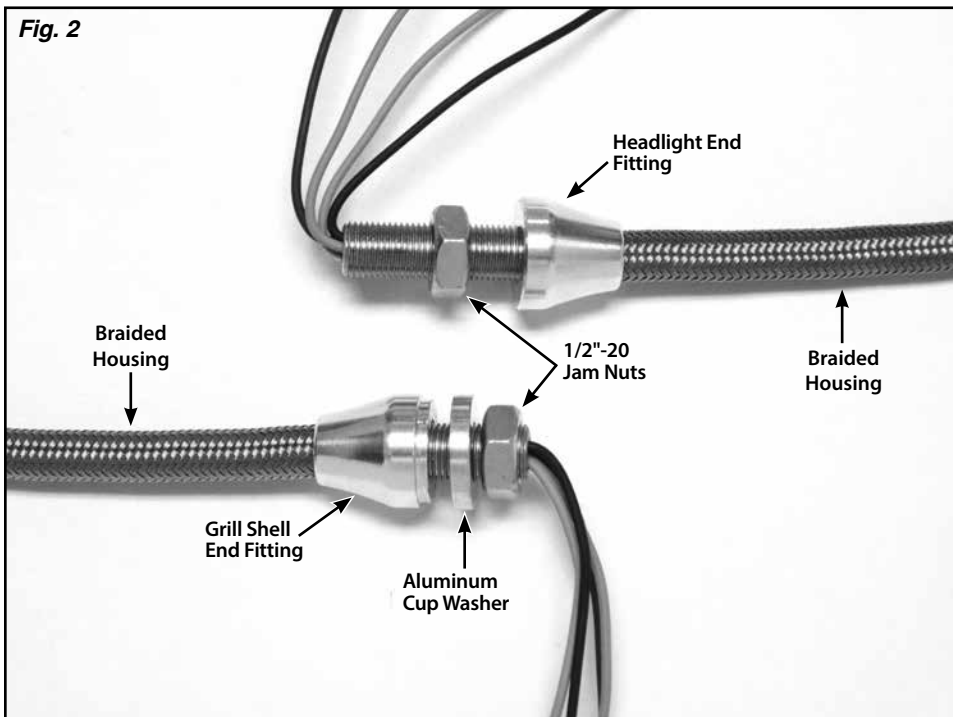

Fig. 4

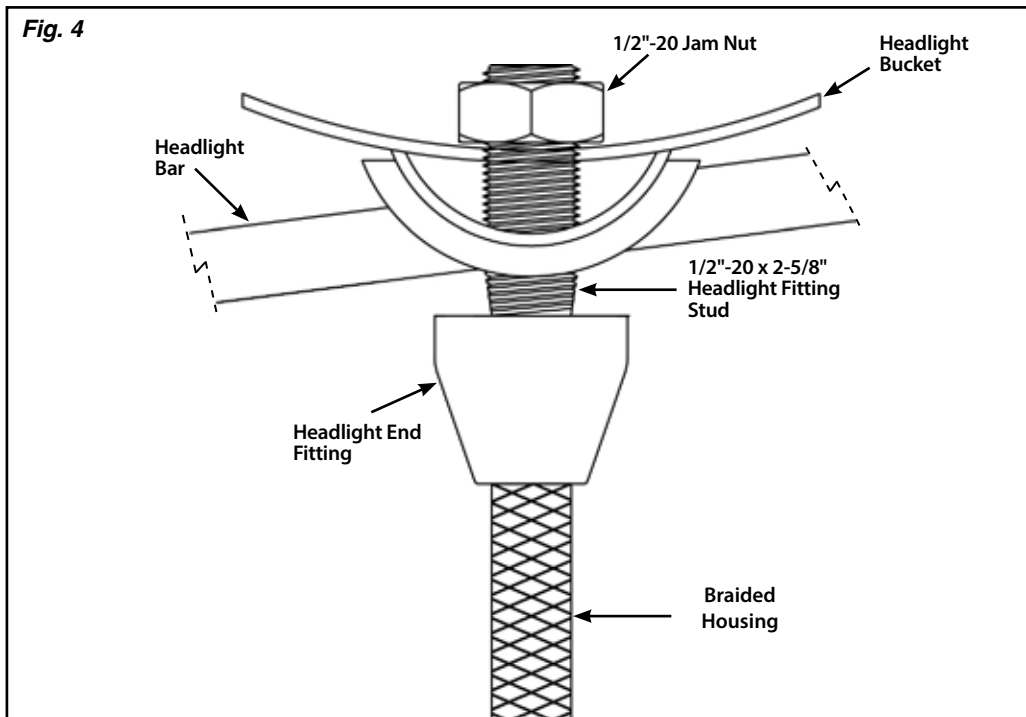

Fig. 3

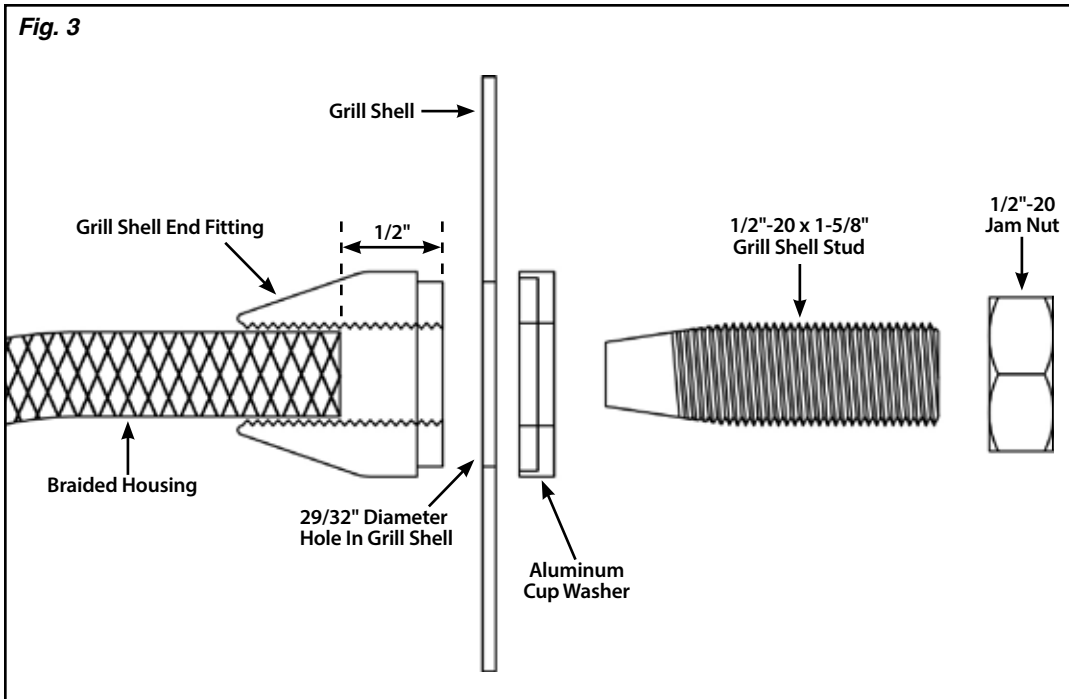

Fig. 5

