



QUALITY... PLAIN & SIMPLE®

## Billet Aluminum Throttle and Kickdown Cable Bracket for Holley Sniper EFI Installation Instructions

# Billet Aluminum Throttle and Kickdown Cable Bracket for Holley Sniper EFI Installation Instructions

Building American Quality... With A Lifetime Warranty!®

TOLL FREE 1-877-469-7440 • tech@lokar.com • www.lokar.com

### General Installation Notes:

Please read these instructions completely before beginning the installation. If you have any questions please call.

Before beginning the installation, disconnect the negative battery cable and use wheel chocks to block the vehicle's wheels.

Make sure the engine, transmission, body and frame are properly grounded. We recommend using anti-seize lubricant on all aluminum threads.

*This kit is designed to be used with a Lokar Throttle Cable and Kickdown Kit (if applicable).*

Refer to Fig. 1 for the component names.

**Step 1:** **TEMPORARILY** remove the button head screw from the left side of the fuel pressure regulator at the fuel outlet using a 3/32" Allen wrench, as shown in Fig. 2

**Step 2:** If the throttle body is already installed, remove the two mounting bolts from the rear of the throttle body. Install the aluminum throttle cable bracket onto the rear of the throttle body base using the two 5/16"-18 x 1-1/2" socket head bolts that are supplied with the kit. Fig. 3

**NOTE:** If you are using a spacer under the carburetor, you will need to supply new socket head bolts that are longer by the same amount as the spacer thickness. Example: a 3/4" spacer requires a 1-1/2" + 3/4" = 2-1/4" socket head bolt.

**Step 3:** **REINSTALL** the button head screw that you removed from the fuel pressure regulator. Tighten using a 3/32" Allen wrench.

**Step 4:** Connect one end of the inner and outer springs to the small hole at the bottom of the aluminum throttle cable bracket. Connect the other end of the inner and outer springs to the rear most hole at the bottom of the throttle lever. Fig. 4

**Step 5:** Install the Lokar Throttle Cable and/or Kickdown Kit according to the instructions included with those parts. The Throttle Cable uses the top hole in the aluminum throttle cable bracket, and the Kickdown uses the lower hole. See Fig. 5 for a completed installation with a Lokar Throttle Cable and Kickdown Kit.

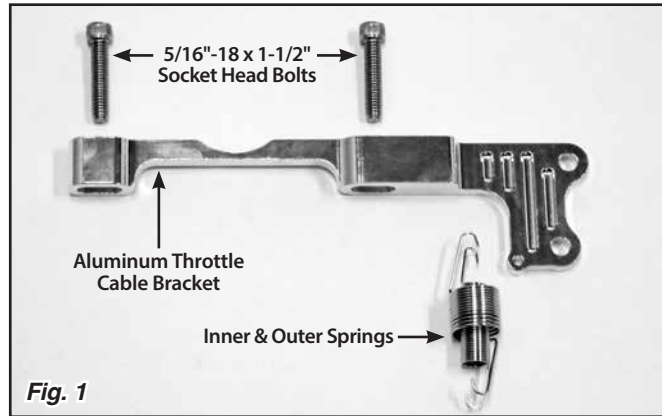

Fig. 1



Fig. 2

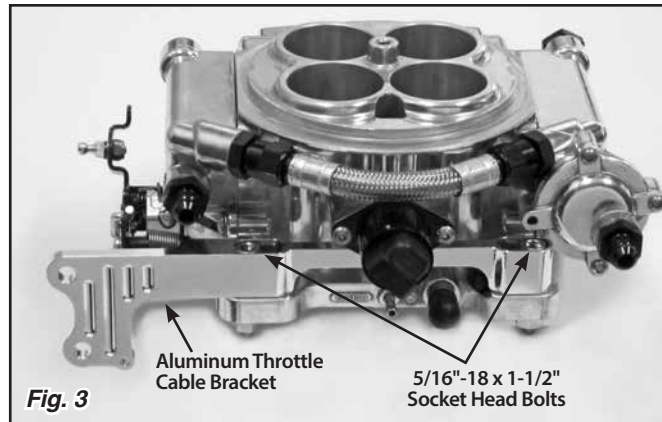

Fig. 3

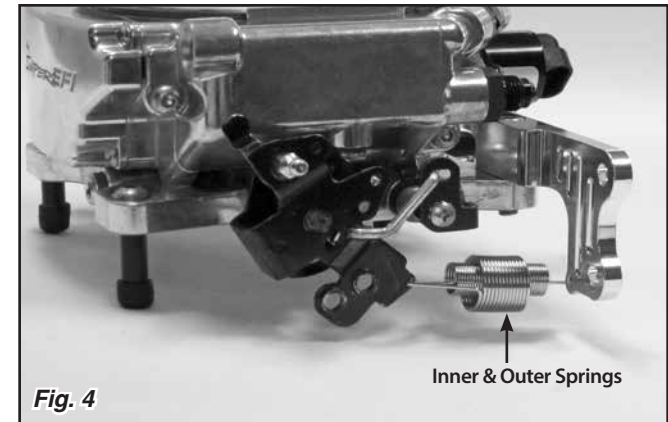

Fig. 4

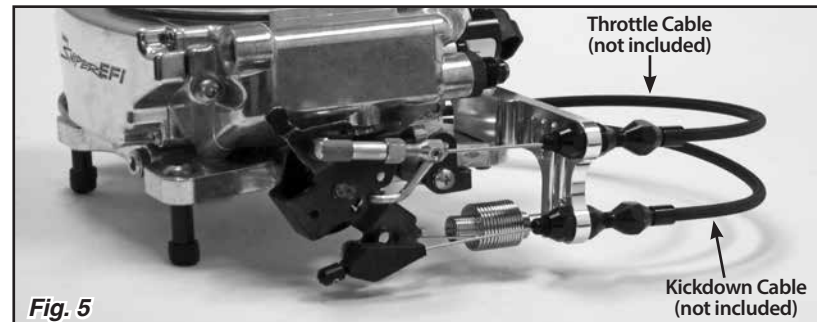

Fig. 5