



QUALITY... PLAIN & SIMPLE®

Push/Pull Throttle Cable Mounting Bracket & Spring Return Kit Installation Instructions

General Installation Notes:

Please read these instructions completely before beginning the installation. If you have any questions please call.

Before beginning the installation, disconnect the negative battery cable and use wheel chocks to block the vehicle's wheels.

Make sure the engine, transmission, body and frame are properly grounded. We recommend using anti-seize lubricant on all aluminum threads.

Refer to Fig. 1 and Fig. 2 for the component names.

Step 1: Remove the 1/4"-20 thin nylock nut and the post washer from the spring stand assembly. Install the spring stand with the springs and throttle tab onto the top side of the throttle cable mounting bracket, into the slot at the front left corner. Install the post washer (beveled edge out) and 1/4"-20 thin nylock nut on the bottom. **Fig. 3**

Step 2: The long cable stand is designed for use with an inline throttle stop, and the short cable stand is designed for use without an inline throttle stop. Determine which cable stand is correct for your application.

Assemble the cable stand and cable stud, using the 7/16"-20 thin nylock nut and flat washer. **Fig. 4** The end of the cable stud that has a #10-32 set screw will point away from the center of the engine.

The hole in the cable stud that the cable passes through is a slightly larger diameter on one side. The larger diameter side goes towards the throttle cable, away from the carburetor. Make sure the cable stud is angled correctly so that the throttle cable will be aligned with the connection point on the carburetor.

Step 3: On the top side of the mounting bracket, insert the appropriate cable stand (long or short, depending on your application) into the slot at the rear left corner, with the cable stud pointing outwards. Install an internal-tooth lock washer and a post washer (beveled edge out) on two of the 1/4"-20 x 3/4" socket head bolts, and install the bolts into the cable stand from the bottom up through the throttle cable mounting bracket. **Fig 5**

Push/Pull Throttle Cable Mounting Bracket & Spring Return Kit Installation Instructions, For 4150 & 4500 Series Carburetors

Building American Quality... With A Lifetime Warranty!®

TOLL FREE 1-877-469-7440 • tech@lokar.com • www.lokar.com

4150 Series Shown

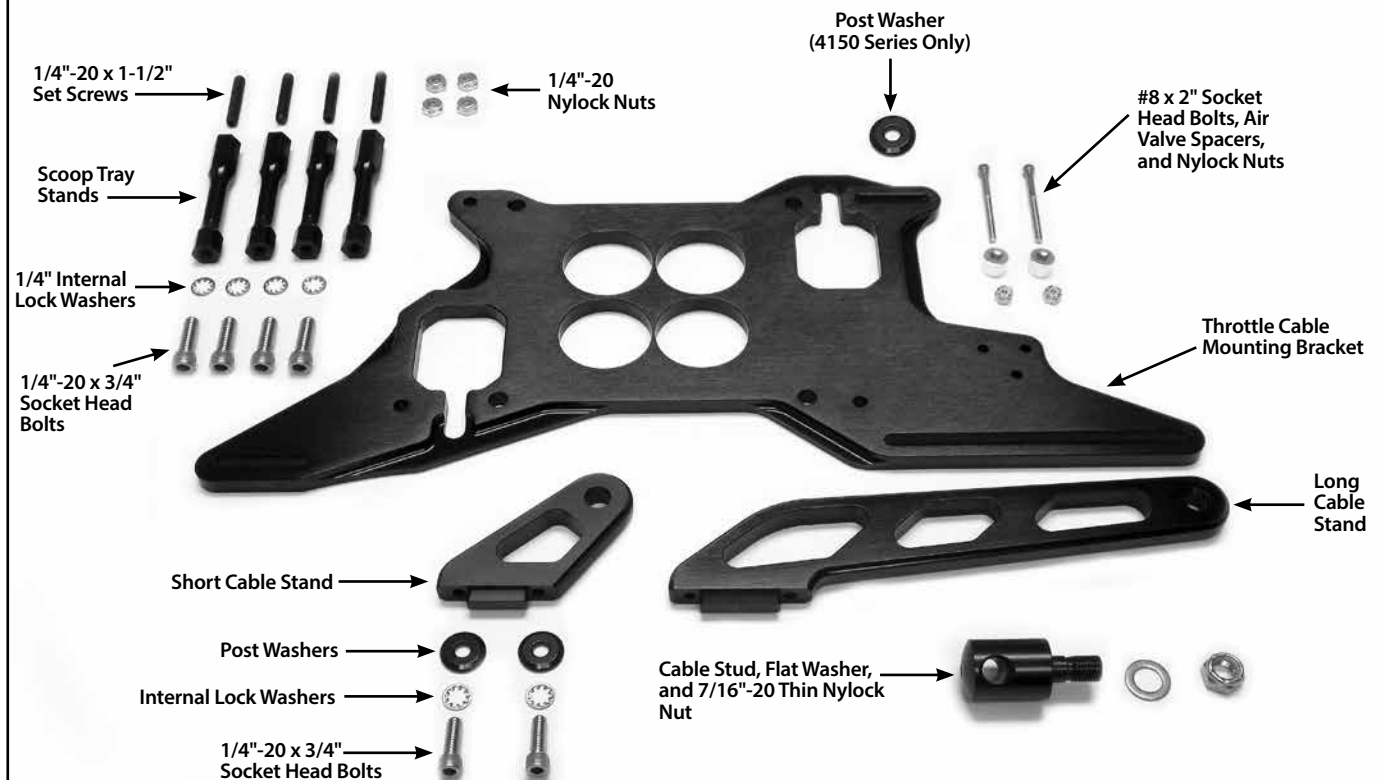
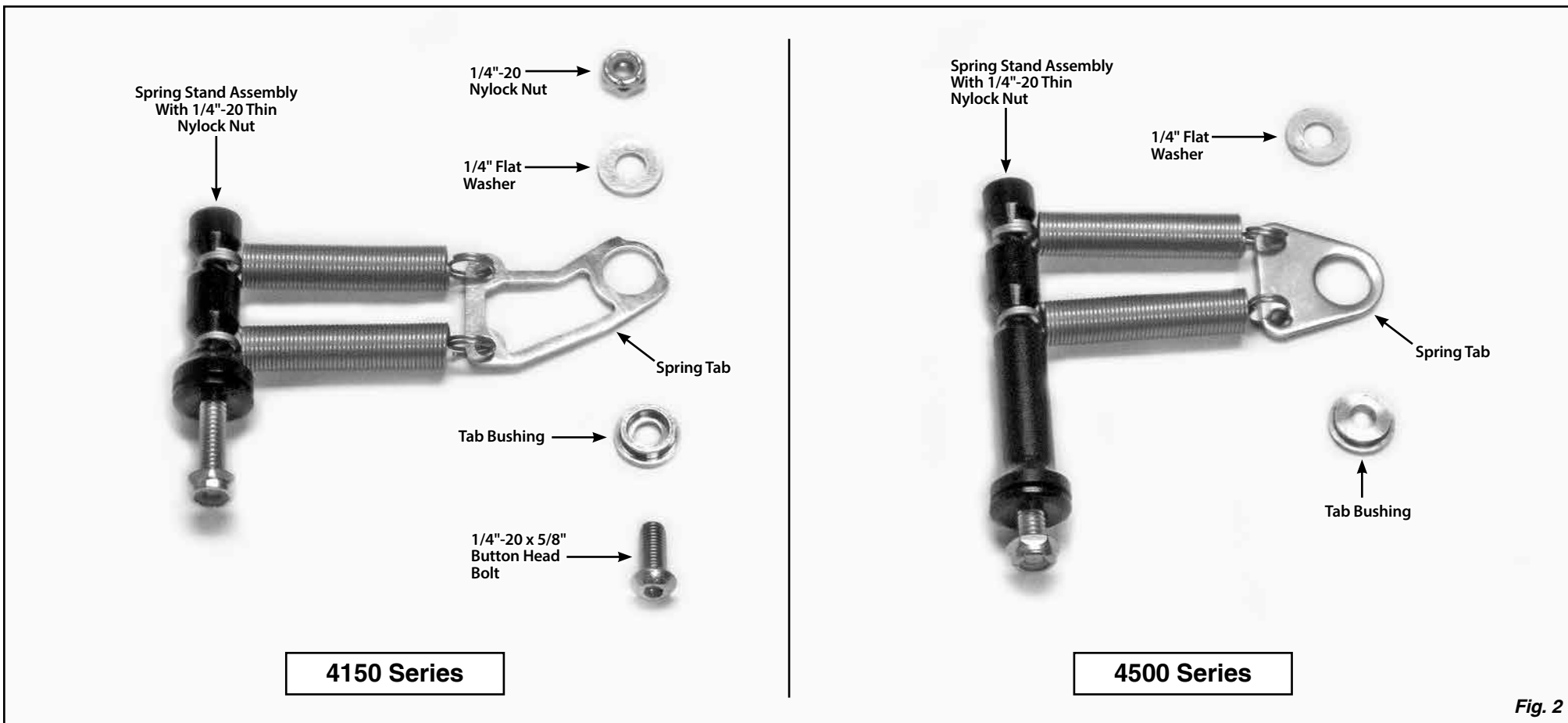

Fig. 1



Step 3 (continued): If you are going to be using a scoop tray, install the scoop tray stands onto the mounting bracket using the 1/4"-20 x 3/4" socket head bolts and internal lock washers. The end of the scoop tray stand that has the shorter hex goes towards the bottom. **4150-Series Applications Only** also use a post washer on the 1/4"-20 x 3/4" socket head bolt at right rear corner, where the scoop tray stand is bolted into a slot instead of a round hole.

Install the 1/4"-20 x 1-1/2" set screws into the top end of each of the scoop tray stands. **Fig. 6**

Step 4: Place a new carburetor gasket (not included) onto the intake manifold. Install the mounting bracket onto the intake manifold with the cable stand and spring assembly on the left. Place a new carburetor gasket (not included) on top of the mounting bracket, and install the carburetor.

Step 5, 4150 Series Carburetors: Place the tab bushing onto the 1/4"-28 x 5/8" button head bolt with the larger diameter side towards the head of the bolt. Insert the button head bolt and the tab bushing into the large round hole in the spring tab. Install this assembly into the return spring hole on the carburetor throttle arm, and secure with the 1/4"-28 nylock nut. Make sure the recess in the tab bushing is seated over the lip on the carburetor throttle arm, and that the spring tab will rotate freely on the tab bushing. **Fig. 7**

Step 5, 4500 Series Carburetors: Place the tab bushing onto your carb linkage stud (not included), with the larger diameter side towards the cable. Insert the carb linkage stud and tab bushing into the spring tab. Install this assembly onto the carburetor throttle arm, and secure with the provided 1/4" flat washer and your original nylock nut (not included). Make sure that the spring tab will rotate freely on the tab bushing. **Fig. 8**

Step 6: Install the throttle cable, making sure it is fully seated in the cable stud. Adjust the angle of the cable stud if needed. Tighten the #10-32 set screw on the end of the cable stud to retain the throttle cable in the cable stud.

If you are using a throttle stop with an air valve, the air valve can be installed onto the throttle cable mounting bracket. Behind the carburetor and to the right of the cable stand, there are three holes in the mounting bracket. The three holes will allow the air valve to be mounted in either of two directions. Mount the air valve using the provided #8-32 x 2" socket head bolts and nylock nuts, with the air valve spacers between the air valve and the mounting bracket.

If you are using a scoop tray, the remaining 1/4"-20 nylock nuts can be used to fasten the scoop tray to the set screws at the top of the scoop tray studs.

See **Fig. 9** and **Fig. 10** for completed installations.

NOTE: Before starting the engine, check the carburetor and throttle linkage to make sure there is no binding and that the throttle returns all the way to the closed position.

4500 Series Shown

