



QUALITY... PLAIN & SIMPLE®

GM Floor Mount Automatic Transmission Shifter Installation Instructions

GM Floor Mount Automatic Transmission Shifter Installation Instructions

Building American Quality... With A Lifetime Warranty!®

TOLL FREE 1-877-469-7440 • tech@lokar.com • www.lokar.com

General Installation Notes:

Please read these instructions completely before beginning the installation. If you have any questions please call.

Before beginning the installation, disconnect the negative battery cable and use wheel chocks to block the vehicle's wheels.

Make sure the engine, transmission, body and frame are properly grounded.

Refer to Fig. 1 for the component names.

Tools and Materials Required:

- Standard Allen wrenches: 1/8", 5/32", 3/16"
- Wrench or Socket Sizes: 3/8", 7/16", 1/2", 9/16", 7/8", 15/16", 13mm (metric transmissions only)
- Tape Measure
- Metal cutting tool, such as a hacksaw or a die grinder with a cut-off wheel
- Drill and 5/16" drill bit
- Ohmmeter
- Wire cutters/strippers
- Wire crimping or soldering tools
- Blue thread locking compound

Lokar Shifters are designed to fit specific transmissions. Before installation, verify that you have the proper model for your transmission. If your Shifter does not seem to connect to the transmission properly, do not make modifications during installation as this may void your warranty. Call for assistance.

Verify that the shifter length you have purchased is what you actually want. When installed, the bottom of the shifter lever will be approximately 3-1/2" - 4" above the bottom of the floor mount mounting bracket. From that point up to the top of the knob is how the shifter length is determined.

The Lokar Floor Mount Shifter is designed to be installed to the rear of the transmission selector shaft. If you need the Shifter to be located close to or in front of the transmission selector shaft, the Lokar Cable Operated Shifter will be a better choice.

The Shifter must be installed into the vehicle before attempting to make any adjustments.

The shifter lever is designed to lock in Park and in Neutral. You must depress the release button in the top of the shifter knob in order to shift out of Park or Neutral. The release button will only be flush with the top of the shifter knob when the shifter lever is in Park or Neutral.

To shift from Park directly to Drive (or Overdrive), depress the release button and hold it down while moving the shifter lever, and the shifter lever will stop in the Drive (or Overdrive) position. Once you release the button, the shifter lever will allow you to move into the next lower gear. You must depress the button to shift down again.

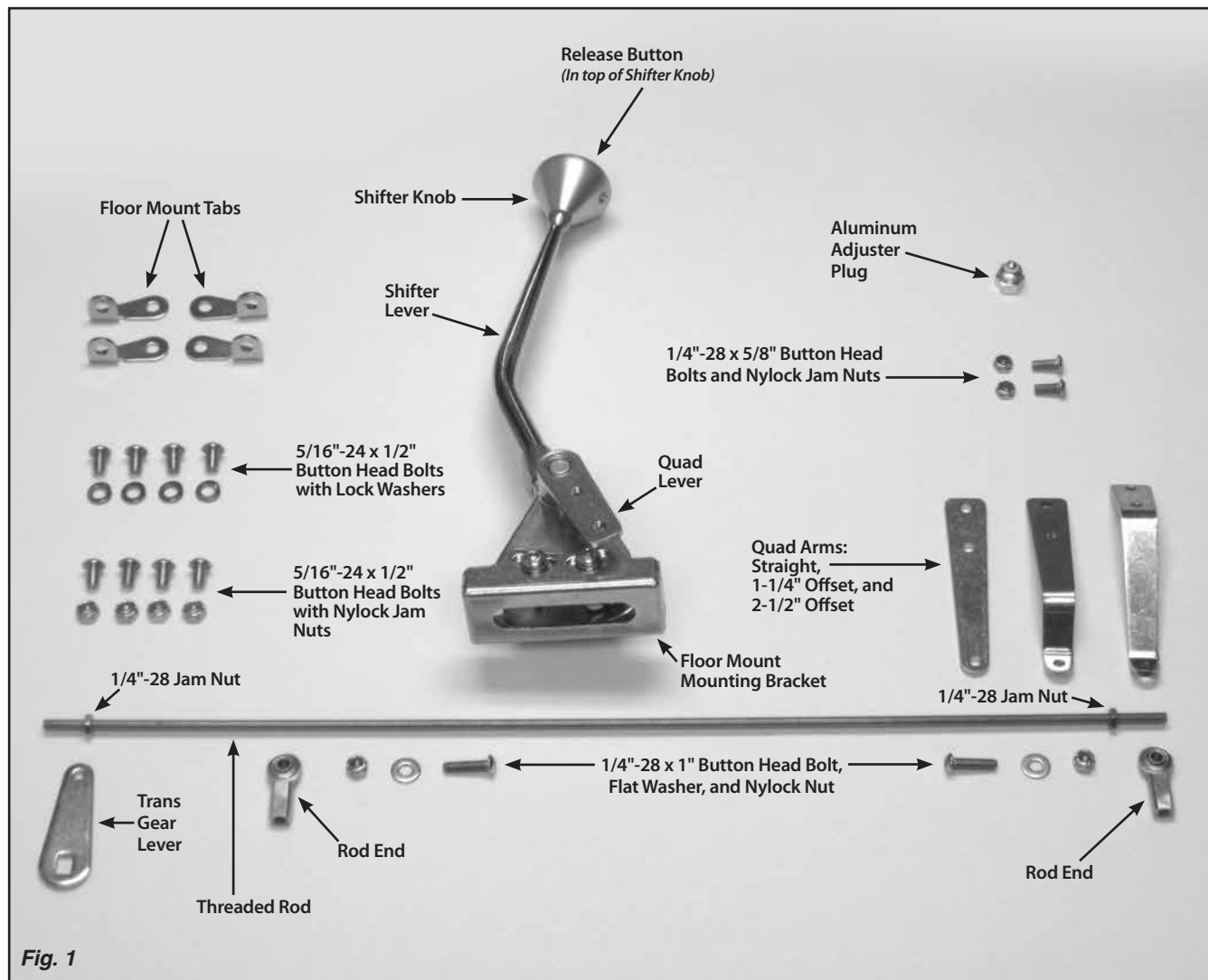

Fig. 1

Step 1: If your vehicle already has a shifter of any type installed, disconnect all shifter linkage and remove the shifter and its related hardware (neutral safety switch, back-up light switch, etc.).

Step 2: Determine exactly where you want the Shifter to be located. The Shifter may be mounted either on top of the floor or underneath the floor.

NOTE: For vehicles that had a floor shifter previously, determine if the existing hole(s) in the floor will be adequate for mounting and operation of the Lokar Shifter. If not, the floor will need to be modified.

If you are mounting the Shifter on top of the floor, you will need a slot in the floor for the quad arm to pass through. If you are mounting the Shifter underneath the floor, the opening will need to be large enough for the floor mount mounting bracket also.

There are three different quad arms to choose from: straight, 1-1/4" offset or 2-1/2" offset. Choose the quad arm that aligns most closely to the trans gear lever on the transmission. It is not necessary that the quad arm be perfectly aligned with the trans gear lever. The rod ends allow for a certain amount of misalignment.

Be aware that the quad arm you choose will affect the size and location of the slot that will need to be cut in the floor.

NOTE: Round Lokar Shifter Boots and Boot Rings will NOT work with a Lokar Floor Mount Shifter if the Shifter Boot and Boot Ring are also mounted directly on the floor.

Rectangular Lokar Shifter Boots and Boot Rings will NOT work with the (largest) 2.5" offset quad arm on a Lokar Floor Mount Shifter if the Shifter Boot and Boot Ring are also mounted directly on the floor.

Step 3: There are two pairs of floor mount tabs in the Shifter Kit. Which pair goes where will depend on if you are mounting the Shifter above or below the floor. See **Fig. 2** to determine how the floor mount tabs need to be positioned for your particular application.

The floor mount tabs on the rear of the Shifter must be installed with the ears pointing towards the rear of the vehicle. If you are using a rectangular Lokar Shifter Boot and Ring mounted directly to the floor, the floor mount tabs on the front of the Shifter must also be installed pointing towards the rear of the vehicle. If you are not using a rectangular Lokar Shifter Boot and Ring, you may install the front floor mount tabs facing either direction.

Attach the floor mount tabs to the floor mount mounting bracket as shown in **Fig. 2** with the 5/16"-24 x 1/2" button head bolts and lock washers. Leave the bolts loose enough so that adjustments can be made later during the installation.

Step 4: Make sure the two 5/16"-24 x 3/8" button head bolts that are in the curved, slotted holes in the left side of the floor mount mounting bracket are tight. Place the Shifter in the desired location on the vehicle's floor. Make sure the shifter lever will not interfere with the dash when in Park, or with the seat when in low gear. The shifter assembly may be tilted forward or backward if needed by loosening the two 5/16"-24 x 3/8" button head bolts that are in the curved, slotted holes in the left side of the floor mount mounting bracket. Retighten the button head bolts in the curved, slotted holes once you have the shifter assembly at the angle you want. **Fig. 3**

If you ever disassemble the shifter assembly, be sure that the 5/16"-24 x 3/8" button head bolts and lock washers are put back into the curved, slotted holes in the floor mount mounting bracket. Installing longer bolts will prevent the shifter from operating.

NOTE: If you find after installation that the shape or length of the shifter lever is not suitable for your application, Lokar has a number of different styles and lengths of Shifter Lever Replacement Kits available for purchase separately through our dealer network.

Step 5: Determine the size and location of any opening(s) that need to be cut in the floor in order to mount the shifter assembly and allow full travel of the quad arm you are going to use. It may be useful to temporarily mount the quad arm to the quad lever and move the shifter lever through its full range of motion, in order to help determine where the cuts need to be made.

Cut those openings now.

Step 6: Place the shifter assembly in position on the vehicle. Push the floor mount tabs flush against the floor, and mark the center of the bolt holes in the floor mount tabs onto the floor. Center punch the marks, and drill four 5/16" diameter holes.

Step 7: Attach the floor mount tabs to the floor using four 5/16"-24 x 1/2" button head bolts and nylock jam nuts. Once the shifter assembly is mounted to the floor, tighten the floor mount tab to floor mount mounting bracket bolts.

Step 8: Make sure the shifter lever is in the Park position. Position the quad arm in place on the quad lever with the bolt holes aligned. Check for interference with the left rear floor mount tab or the vehicle floor. With the shifter lever in Park, you want the quad arm to be as close to the 4:30 – 5:00 position as the floor mount tab will allow, without the quad arm touching the floor mount tab or floor.

If the quad arm is not in the proper position, loosen the set screw in the top of the quad lever with a 1/8" Allen wrench and slide the quad lever off of the shaft. The shifter assembly may have to be removed to do this, depending on how large the opening is in the tunnel. Reposition the quad lever on the shaft as close to 4:30 – 5:00 as the floor mount tab allows, and retighten the set screw. **Fig. 4**

Install the quad arm onto the quad lever using the two 1/4"-28 x 5/8" button head bolts and nylock jam nuts. **Fig. 4**

Above Floor Installation

Front Floor Mount Tabs pointed rearward for Shifter Boot Ring clearance

Floor Mount Tabs

Floor Mount Tab

5/16"-24 x 1/2" Button Head Bolts with Lock Washers

Below Floor Installation

Front Floor Mount Tabs pointed rearward for Shifter Boot Ring clearance

Floor Mount Tabs

Floor Mount Tab

5/16"-24 x 1/2" Button Head Bolts with Lock Washers

Fig. 2

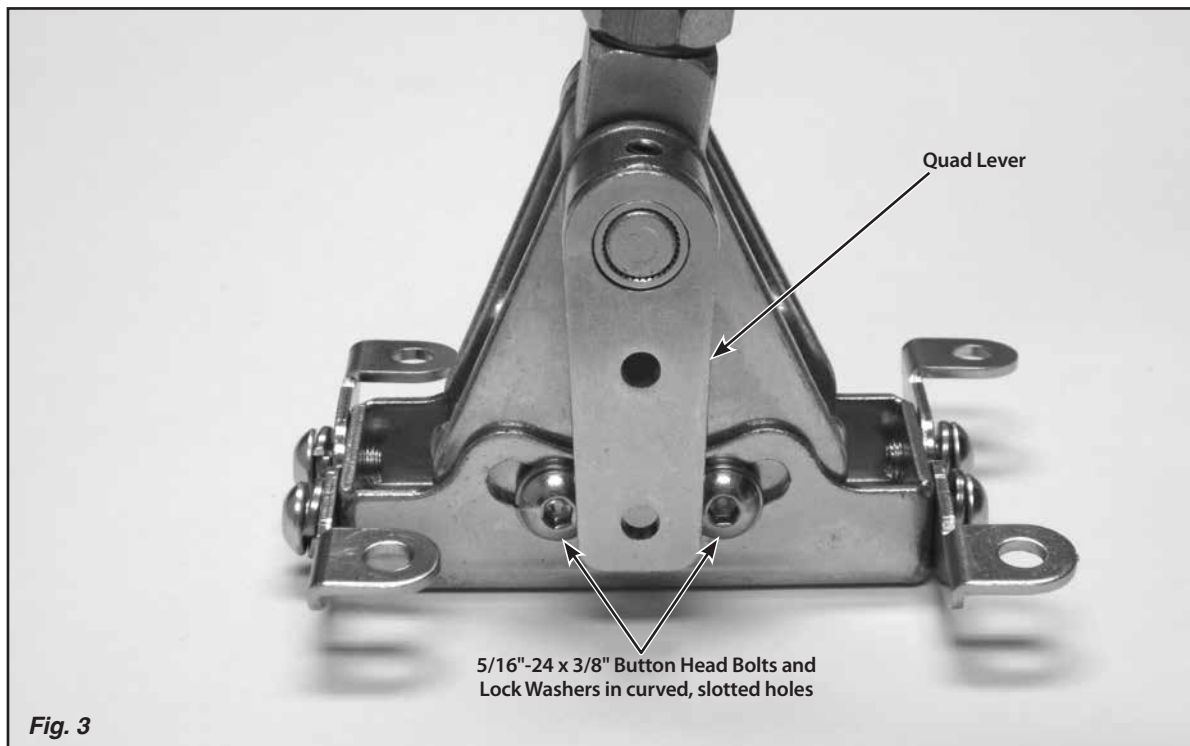

Fig. 3

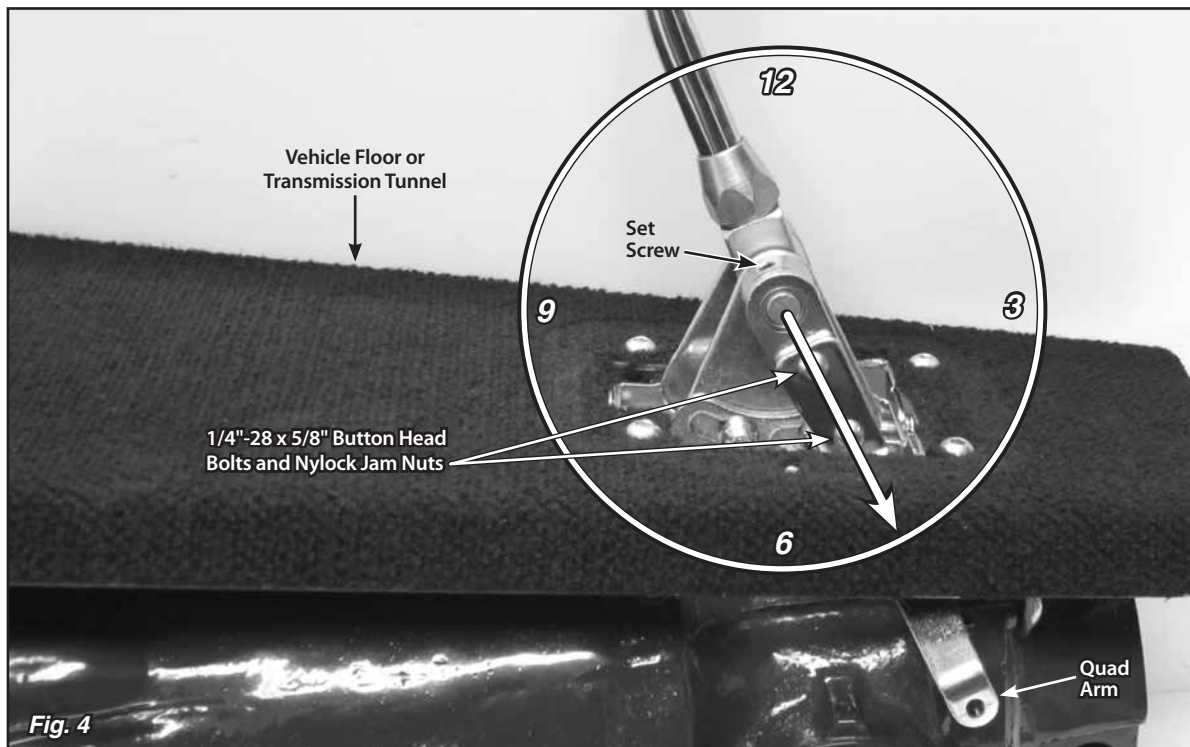

Fig. 4

Step 9: Make sure the transmission is in Park by rotating the original trans gear lever clockwise as far as it will go. Remove the original nut and trans gear lever from the transmission selector shaft. Remove the rod end from the new trans gear lever. Install the new trans gear lever onto the selector shaft, pointed up and slightly towards the rear, at approximately the 1:00 position.

Secure the new trans gear lever with your original nut. **Fig. 5**

Step 10: The threaded rod will connect the quad arm to the trans gear lever. Check to make sure that nothing will interfere with the travel of the threaded rod. Some transmission cases have an external casting feature that may need to be trimmed slightly with a grinder to prevent interference with the threaded rod, depending on the location of your shifter.

If there is any interference, the threaded rod can be bent slightly as needed.

4L60E transmissions with a Manual Lever Position Sensor (MLPS) on the selector shaft will likely require an offset bend in the threaded rod in order to clear the sensor.

Verify that both the shifter lever and the transmission are in the Park position. Measure center-to-center between the 1/4" holes in the trans gear lever on the transmission and the quad arm on the Shifter. Subtract 1-3/4". **Fig. 6** This is the length you will cut the threaded rod to. Use a hacksaw or cutoff wheel to shorten the threaded rod.

Step 11: Make sure that two 1/4"-28 jam nuts are installed on the threaded rod, one at each end. Install a rod end onto each end of the threaded rod. Position the rod ends on the inside or outside of the quad arm and trans gear lever so that the threaded rod is as straight as possible. Attach the threaded rod assembly to the quad arm and trans gear lever using the 1/4"-28 x 1" button head bolts, flat washers, and nylock nuts as shown in **Fig. 7**. The button head bolts can be installed from either direction, but make sure the rod ends are sandwiched between the flat washers and the quad arm or trans gear lever. **Fig. 8**

Step 12: Check the adjustment of the shifter linkage by placing the shifter lever all the way forward into the Park position. Make sure that the release button still moves up and down freely. The release button should be flush with the knob in Park and Neutral. In the Reverse position, you cannot pull the lever back into Neutral without depressing the release button.

While the shifter lever is in the Park position, make sure the transmission is firmly in the "Park" detent, with no tension on the threaded rod. You can verify this by removing the 1/4"-28 x 1" button head bolt with nylock nut that attaches the rod end to the quad arm or trans gear lever at either end of the threaded rod. Make sure the hole in the rod end exactly aligns with the hole in the quad arm or trans gear lever. The bolt should pass freely through both holes at the same time without binding. Do not force the holes to line up.

If the holes are not aligned, screw the rod end in or out just enough to be able to slide the bolt in and out without putting tension on the threaded rod. Make sure that the quad arm and trans gear lever do not move during the adjustment procedure. Use this adjustment routine until the bolt will pass freely in and out of both the rod end and the quad arm or trans gear lever. Reinstall the 1/4"-28 nylock nut and the flat washer in its proper position onto the bolt, and tighten.

Once you have the shifter linkage adjusted correctly, tighten the jam nuts on the threaded rod.

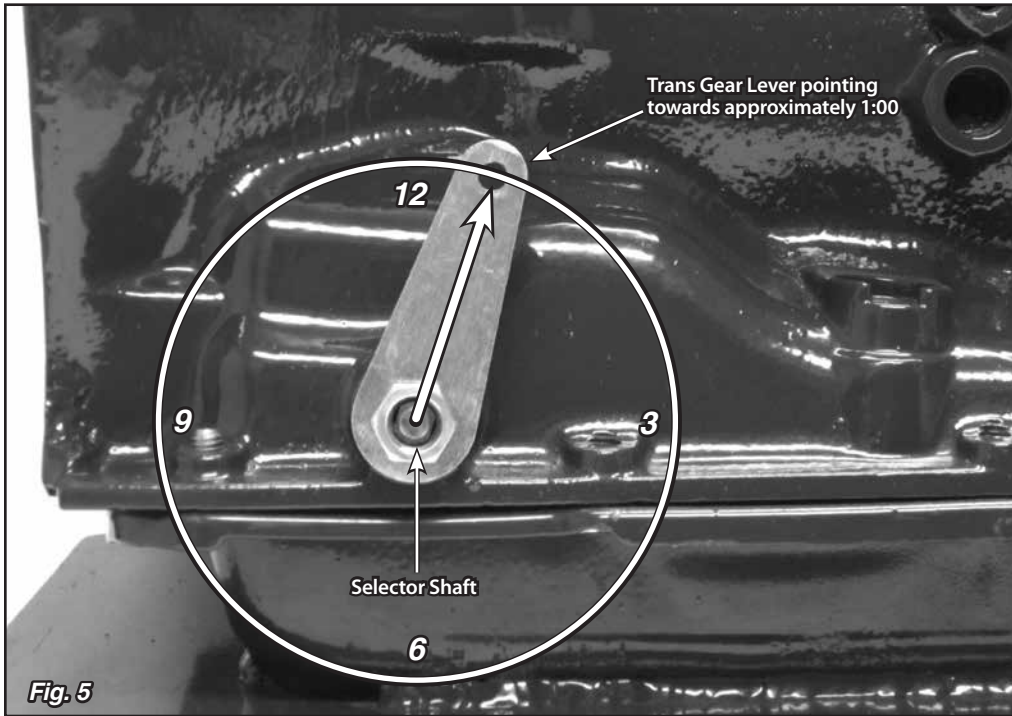

Fig. 5

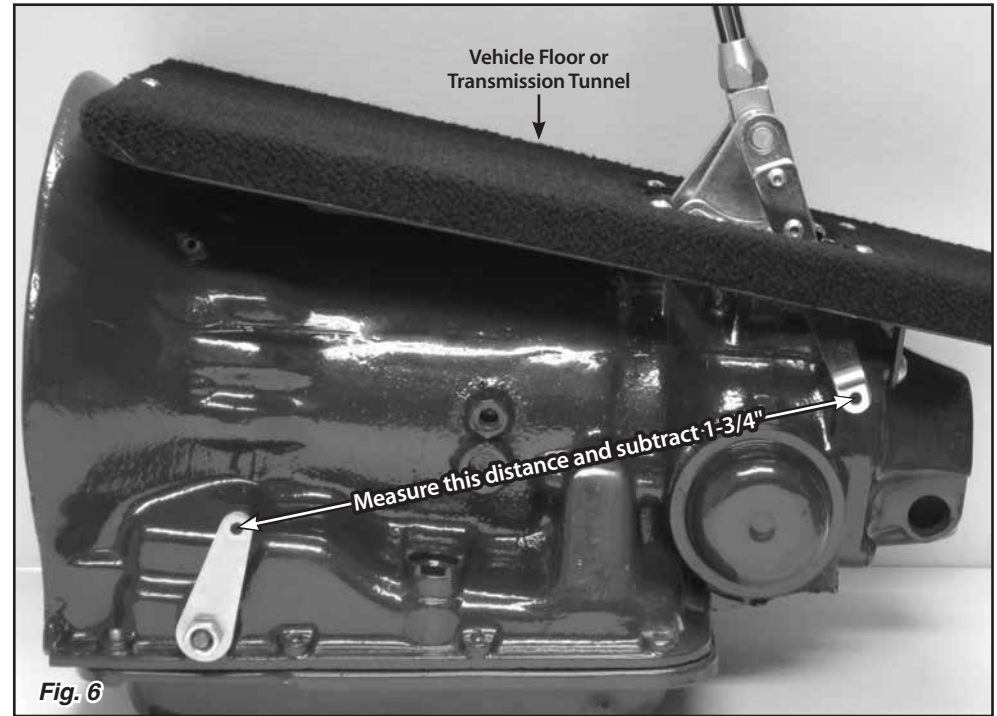

Fig. 6

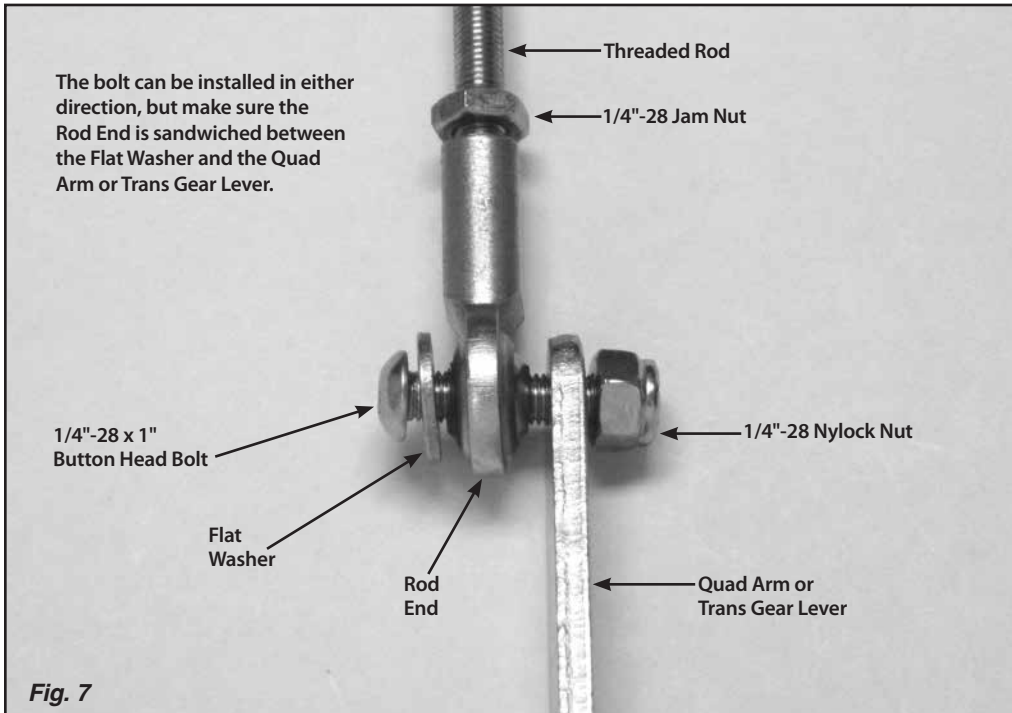

Fig. 7

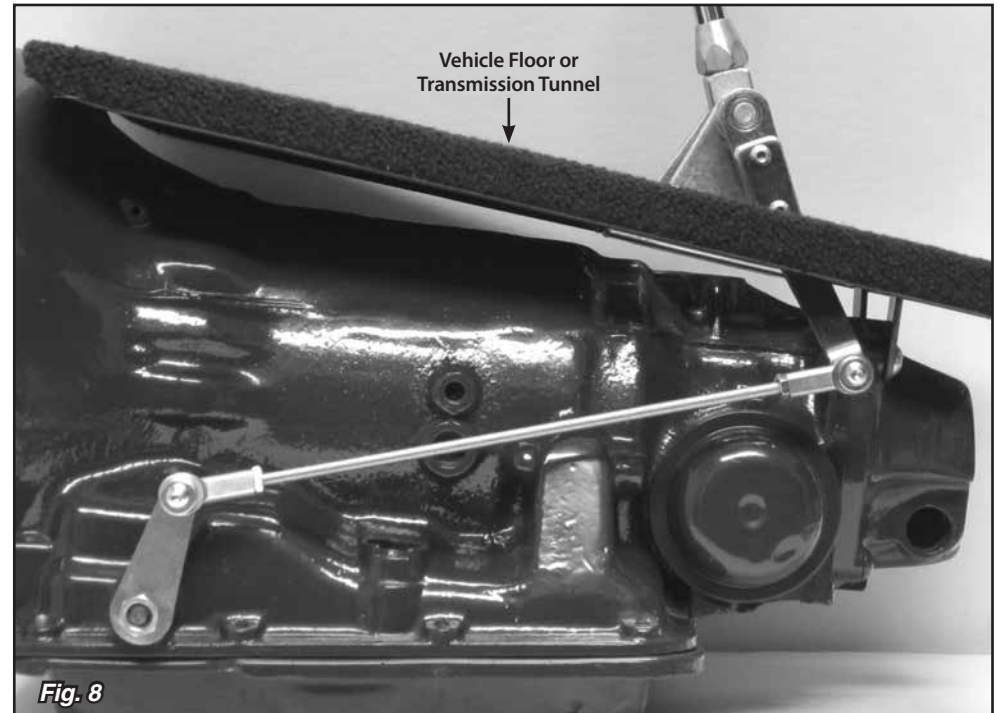

Fig. 8

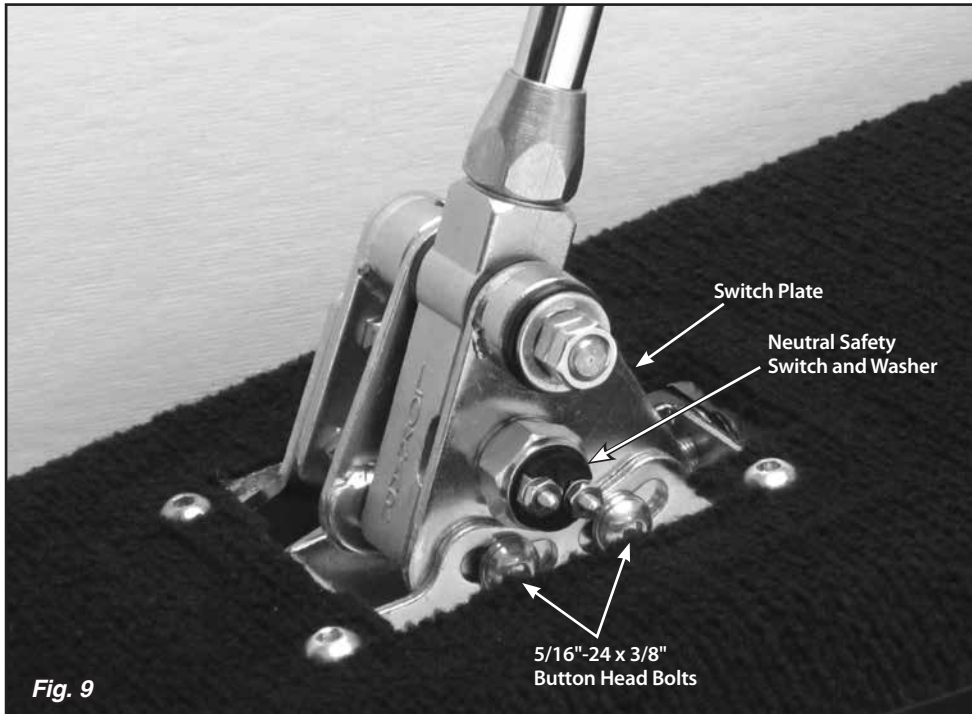

Fig. 9

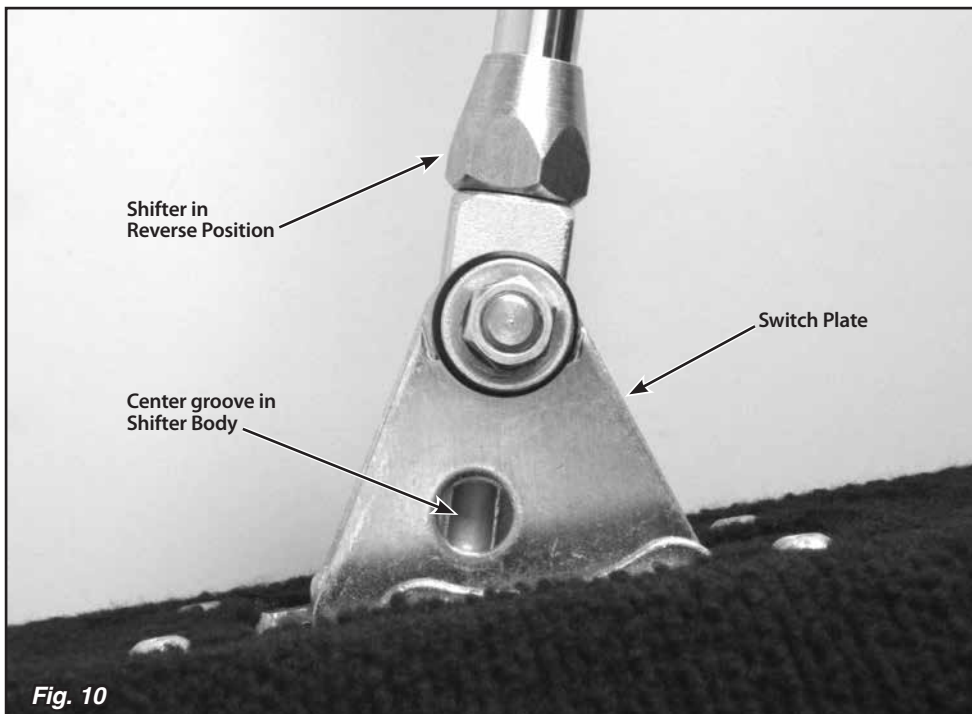

Fig. 10

Neutral Safety Switch Adjustment and Wiring

Step 13: For the neutral safety switch to function properly, the shifter linkage must be adjusted correctly. Do not attempt to adjust the neutral safety switch unless you have completed **Step 12**.

The Lokar Neutral Safety Switch is a simple on/off, non-directional switch. The switch passes current (turns on) when the ball is pushed in. It does not pass current (turns off) when the ball is out at its at-rest position.

Double check to make sure that the bolts in the curved, slotted holes on the left side of the floor mount mounting bracket are tight.

Step 14: Remove the neutral safety switch and washer (**Fig. 9**) from the right side of the Shifter using a 7/8" wrench or socket.

Step 15: Loosen, but do not remove, the two 5/16"-24 x 3/8" button head bolts that attach the right side of the floor mount mounting bracket to the switch plate (the bolts are in curved, slotted holes). **Fig. 9**

WARNING: Before taking the shifter lever out of Park, be sure that the vehicle's tires are blocked and the parking brake is set to avoid movement of the vehicle.

Step 16: Put the shifter into the Reverse position. Reposition the switch plate so that the hole in the switch plate lines up with the center groove in the shifter body. **Fig. 10** Screw the provided aluminum adjuster plug into the neutral safety switch opening. Wiggling the switch plate slightly forward and back while you are screwing the aluminum adjuster plug in will help get the shifter body centered on the adjuster plug. **Fig. 11**

Step 17: Retighten the two 5/16"-24 x 3/8" button head bolts that attach the right side of the floor mount mounting bracket to the switch plate.

Step 18: Remove the aluminum adjuster plug, and reinstall the neutral safety switch and washer onto the shifter. Test for continuity by connecting an ohmmeter lead to each stud on the neutral safety switch. When adjusted correctly, you will only have continuity between the two switch studs when the shifter is in Park or Neutral. Continuity in any other gear requires readjustment of the neutral safety switch or the shifter linkage.

Step 19: Connect the neutral safety switch between your ignition switch and starter circuits. Check the wiring of your fuse panel:

- **If there are (2) connections for a neutral safety switch**, run a #12 (or heavier) stranded wire from these terminals in your fuse panel to the (2) terminals on the neutral safety switch. That completes the Neutral Safety Switch wiring.
- **If your fuse panel does not have neutral safety switch connections**, locate the wire going from the ignition switch to the starter. If GM color codes are used, this wire will usually be purple. After locating the wire, disconnect it from the starter. It must be cut and routed from the ignition switch to one of the neutral safety switch terminals, and from the other neutral safety switch terminal to the same stud on the starter where the original wire was removed. If the wire must be lengthened, be sure to use wire that is at least the same size or larger than the original.

Step 20: Reconnect the negative battery cable and check operation. Make sure that the engine will not start in reverse or a drive gear. If it does, follow the neutral safety switch adjustment procedure again. If your car should ever start in any gear other than Park or Neutral, please readjust the neutral safety switch accordingly. Tighten all brackets and bolts correctly and securely and there should be no movement or maladjustment. If you have any questions after following this procedure, please call Lokar Technical Support.

Step 21: Once the installation is completely finished and the neutral safety switch is adjusted, remove each of the 5/16"-24 x 3/8" button head bolts from the curved, slotted holes in the floor mount mounting bracket one at a time, apply blue thread locking compound to the threads, and reinstall.

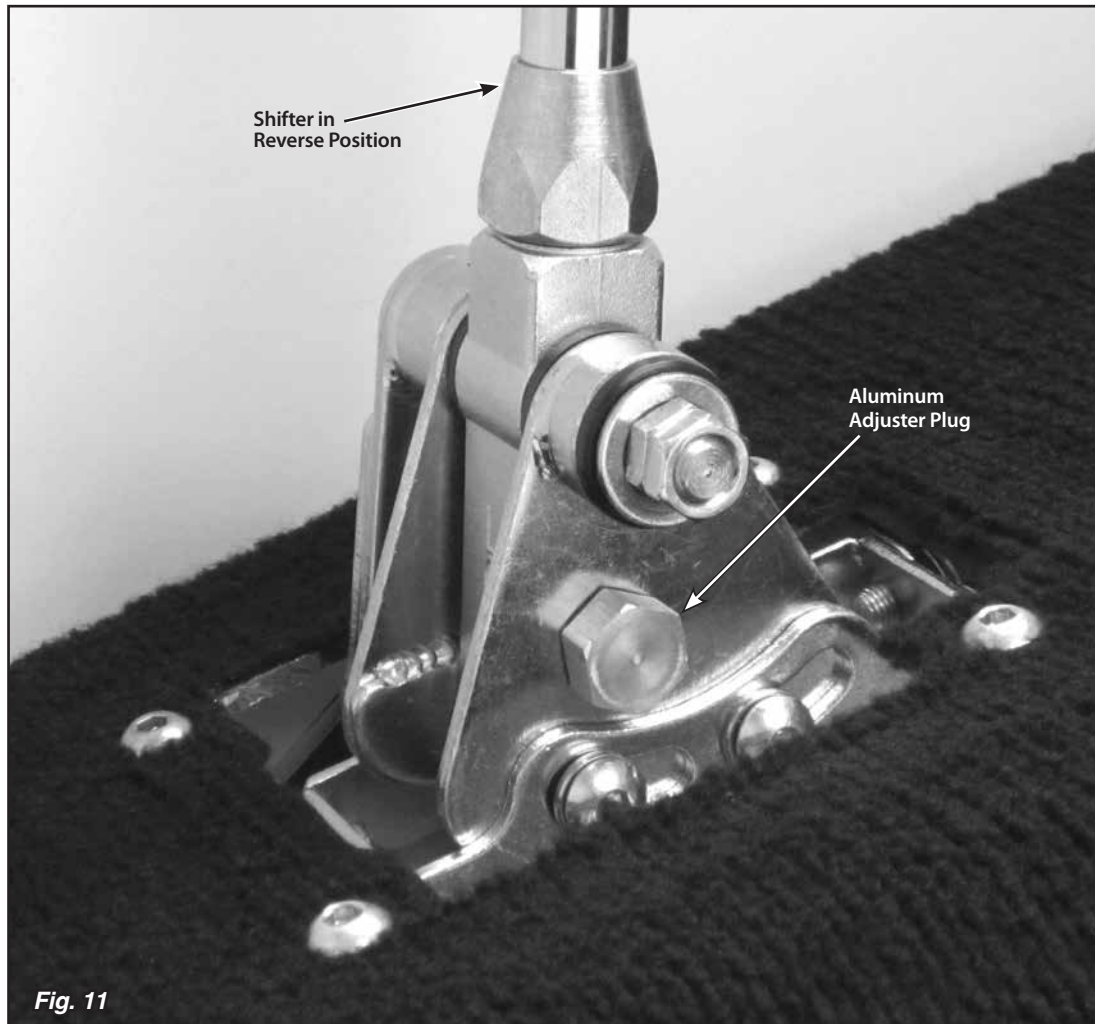

Fig. 11

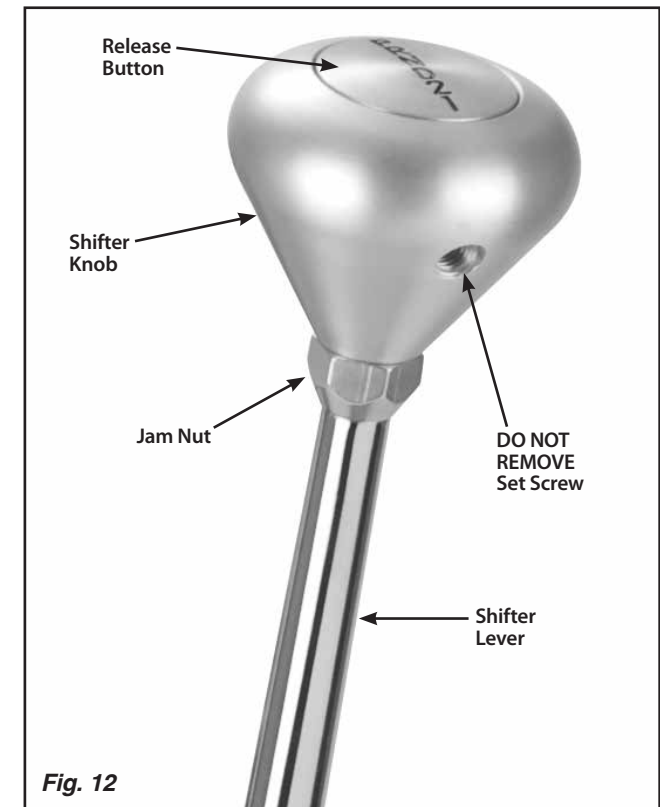

Fig. 12

Lokar Shifter Knob Removal Instructions (For Shifters Manufactured 1995 and Later)

For Shifters manufactured 1994 and earlier, please contact Lokar for assistance.

To Remove Shifter Knob:

- Step 1:** Make sure the Shifter is all the way forward in the Park position.
- Step 2:** Loosen the jam nut below the shifter knob. **DO NOT** loosen or remove the set screw that is in the knob. **Fig. 14**
- Step 3:** Turn the shifter knob counter-clockwise to remove.

To Install Shifter Knob:

- Step 1:** Make sure the jam nut is still in place on the shifter lever.
- Step 2:** Screw the shifter knob onto the shifter lever until the release button comes up flush with the top of the shifter knob.
- Step 3:** Tighten the jam nut up against the bottom of the shifter knob.
- Step 4:** Check to make sure that depressing the release button allows the shifter lever to be moved, and that the shifter lever still locks in Park and Neutral. If the Shifter will not come out of "PARK" with the release button fully depressed, tighten the knob one turn and check it again. If the Shifter does not lock in "PARK", loosen the knob one turn and check it again.