

Ford C4 and C6 Gated Automatic Transmission Shifter Installation Instructions



Ford C4 and C6 Gated Automatic Transmission Shifter Installation Instructions

Building American Quality... With A Lifetime Warranty!

TOLL FREE 1-877-469-7440 • tech@lokar.com • www.lokar.com

General Installation Notes:

Please read these instructions completely before beginning the installation. If you have any questions, please call.

Before beginning the installation, disconnect the negative battery cable and use wheel chocks to block the vehicle's wheels.

Make sure the engine, transmission, body and frame are properly grounded. We recommend using anti-seize lubricant on all aluminum threads.

Refer to Fig. 1 for the component names.

Tools and Materials Required:

- Standard Allen wrenches: 1/8", 5/32", 3/16"
- Wrench or Socket Sizes: 3/8", 7/16", 1/2", 9/16", 7/8", 15/16",
- Tape Measure
- Metal cutting tool, such as a hacksaw or a die grinder with a cut-off wheel
- Drill and 5/16" drill bit
- Ohmmeter
- Wire cutters/strippers
- Wire crimping or soldering tools
- Blue thread locking compound

This Clayton Machine Works Shifter is designed to fit a specific transmission model. Before installation, verify that you have the proper Shifter for your transmission. If your Shifter does not seem to connect to the transmission properly, do not make modifications during installation as this may void your warranty. Call for assistance.

The Clayton Machine Works Shifter is designed to be installed to the rear of the transmission selector shaft. If you need the Shifter to be located close to or in front of the transmission selector shaft, you will need a Bell Crank Kit or a Shifter Cable Conversion Kit (available separately).

The Shifter must be installed into the vehicle before attempting to make any adjustments.

This Shifter is offered either with a pre-installed round tubular Shifter Lever, or with a stub designed to accept a Tremec style bolt on Shifter lever (as pictured in these instructions, Shifter Lever available separately but not included). The installation of both styles of Shifter is the same.

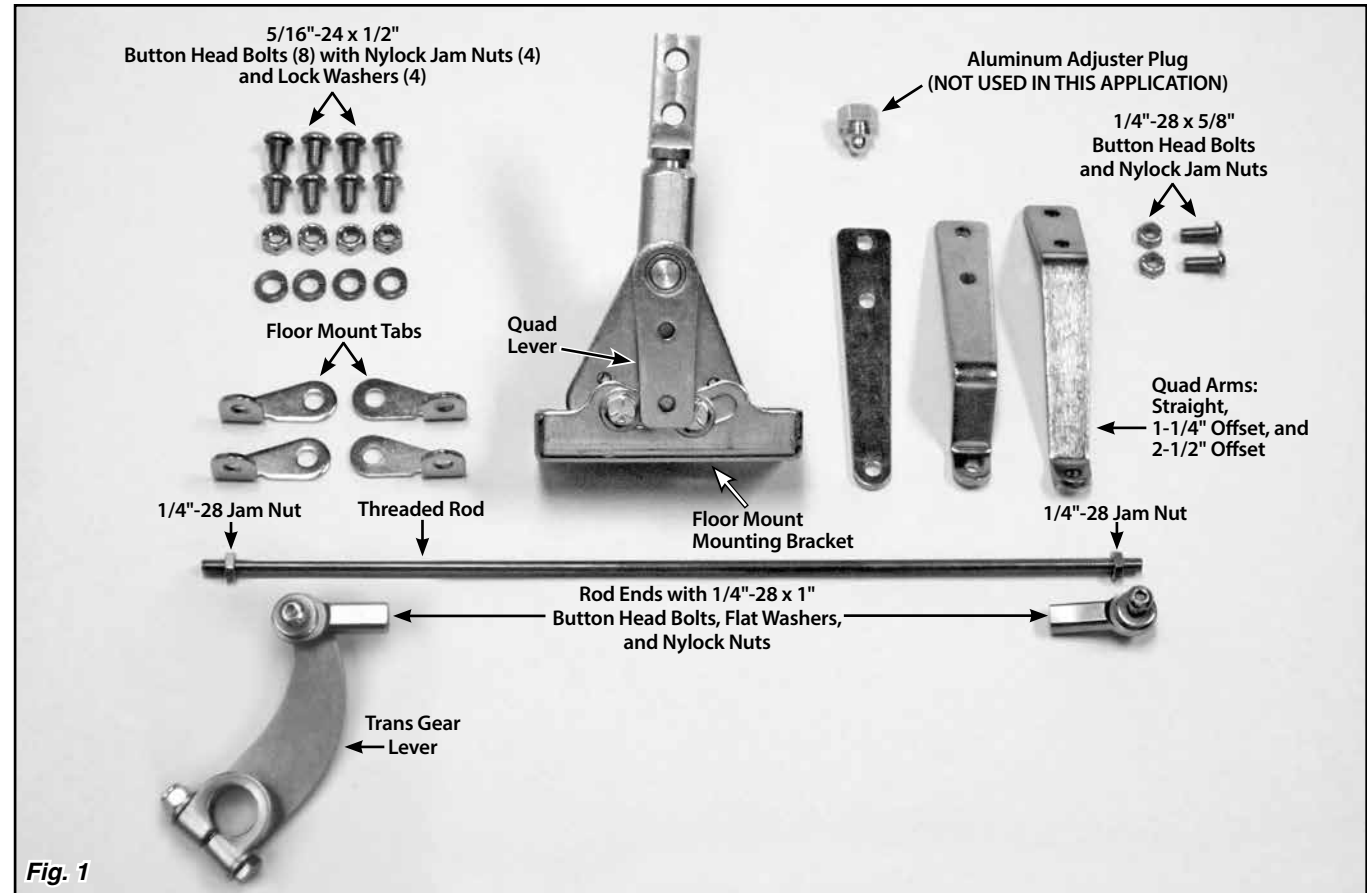

Fig. 1

To move the Shifter out of Park, pull the Shifter Lever towards the driver side, and then pull the Shifter Lever rearward into Reverse. Pull the Shifter Lever rearward again to go into Neutral. Let go of the Shifter Lever, and it will spring back towards the passenger side. The Shifter Lever can then be pulled rearward again into Drive. To access the lower gears, move the Shifter Lever towards the driver side again, and pull rearward.

Step 1: If your vehicle already has a shifter of any type installed, disconnect all shifter linkage and remove the shifter and its related hardware (neutral safety switch, back-up light switch, etc.).

Step 2: Determine exactly where you want the Shifter to be located. The Shifter may be mounted either on top of the floor or underneath the floor.

NOTE: For vehicles that had a floor shifter previously, determine if the existing hole(s) in the floor will be adequate for mounting and operating the Clayton Machine Works Shifter. If not, the floor will need to be modified.

If you are mounting the Shifter on top of the floor, you will need a slot in the floor for the quad arm to pass through. If you are mounting the Shifter underneath the floor, the opening will need to be large enough for the floor mount mounting bracket also.

(continued on Page 2)

Step 2, continued: There are three different quad arms to choose from: straight, 1-1/4" offset or 2-1/2" offset. Choose the quad arm that aligns most closely to the trans gear lever on the transmission. It is not necessary that the quad arm be perfectly aligned with the trans gear lever. The rod ends allow for a certain amount of misalignment.

Be aware that the quad arm you choose will affect the size and location of the slot that will need to be cut in the floor.

NOTE: Some round shifter boots and boot rings will NOT work with a Clayton Machine Works Shifter if the Shifter Boot and Boot Ring are also mounted directly on the floor.

Some shifter boots and boot rings will NOT work with the (largest) 2.5" offset quad arm on a Clayton Machine Works Shifter if the Shifter Boot and Boot Ring are also mounted directly on the floor.

Step 3: There are two pairs of floor mount tabs in the Shifter Kit. Which pair goes where will depend on if you are mounting the Shifter above or below the floor. See **Fig. 2** to determine how the floor mount tabs need to be positioned for your particular application.

The floor mount tabs on the rear of the Shifter **must** be installed with the ears pointing towards the rear of the vehicle. You may install the front floor mount tabs facing either direction, but installing the front floor mount tabs pointing rearward is less likely to interfere with fitment of a shifter boot and boot ring.

Attach the floor mount tabs to the floor mount mounting bracket as shown in **Fig. 2** with the 5/16"-24 x 1/2" button head bolts and lock washers. Leave the bolts loose enough so that adjustments can be made later during the installation.

Step 4: Tremec Style Lever - If your Shifter did not come with the Shifter Lever already installed, install the Shifter Lever using the 3/8"-24 bolts that came with the Shifter Lever. **Fig. 3**

All: Make sure the two 5/16"-24 x 2-1/4" hex head bolts and nylock nuts that are in the curved, slotted holes in the floor mount mounting bracket are tight. Place the Shifter in the desired location on the vehicle's floor. Make sure the Shifter Lever will not interfere with the dash when in Park, or with the seat when in low gear. The shifter assembly may be tilted forward or backward if needed by loosening the nylock nuts on the two 5/16"-24 x 2-1/4" hex head bolts that are in the curved, slotted holes in the floor mount mounting bracket. Retighten the nylock nuts once you have the shifter assembly at the angle you want. **Fig. 4**

Step 5: Determine the size and location of any opening(s) that need to be cut in the floor in order to mount the shifter assembly and allow full travel of the quad arm you are going to use. It may be useful to temporarily mount the quad arm to the quad lever and move the shifter lever through its full range of motion, in order to help determine where the cuts need to be made.

Cut those openings now.

Step 6: Place the shifter assembly in position on the vehicle. Push the floor mount tabs flush against the floor, and mark the center of the bolt holes in the floor mount tabs onto the floor. Center punch the marks, and drill four 5/16" diameter holes.

Step 7: Attach the floor mount tabs to the floor using four 5/16"-24 x 1/2" button head bolts and nylock jam nuts. Once the shifter assembly is mounted to the floor, tighten the floor mount tab to floor mount mounting bracket bolts using a 3/16" Allen wrench.

Step 8: Make sure the shifter lever is in the Park position. Position the quad arm in place on the quad lever with the bolt holes aligned. Check for interference with the driver side rear floor mount tab or the vehicle floor. With the shifter lever in Park, you want the quad arm to be as close to the 4:30 – 5:00 position as the floor mount tab will allow, without the quad arm touching the floor mount tab or floor.

If the quad arm is not in the proper position, loosen the set screw in the top of the quad lever with a 1/8" Allen wrench and slide the quad lever off of the shaft. The shifter assembly may have to be removed to do this, depending on how the Shifter is mounted and how large the opening is in the tunnel. Reposition the quad lever on the shaft as close to 4:30 – 5:00 as the floor mount tab allows, and retighten the set screw. **Fig. 5**

Install the quad arm onto the quad lever using the two 1/4"-28 x 5/8" button head bolts and nylock jam nuts. **Fig. 5**

Step 9: Make sure the transmission is in Park by rotating the original trans arm clockwise as far as it will go. Remove the rod end from the new trans arm. Remove the tape from the pinch bolt, and position the trans arm with the pinch bolt, flat washers, and nylock nut onto the transmission gear selector shaft. The trans arm should be pointing up and slightly towards the rear, with the inside of the curve facing the front of the transmission like a backwards "C". The 1/4" hole in the end of the trans arm should be at approximately the 1:00 position.

If your original trans arm interferes with the new trans arm, the original trans arm must be cut off of the selector shaft. It is much easier to cut the trans arm off of the selector shaft if you remove the selector shaft from the transmission first. If you remove the selector shaft, we recommend that you install a new selector shaft seal (not included) when reassembling.

Tighten the nylock nut on the pinch bolt to hold the trans arm in position on the selector shaft. **Fig. 6**

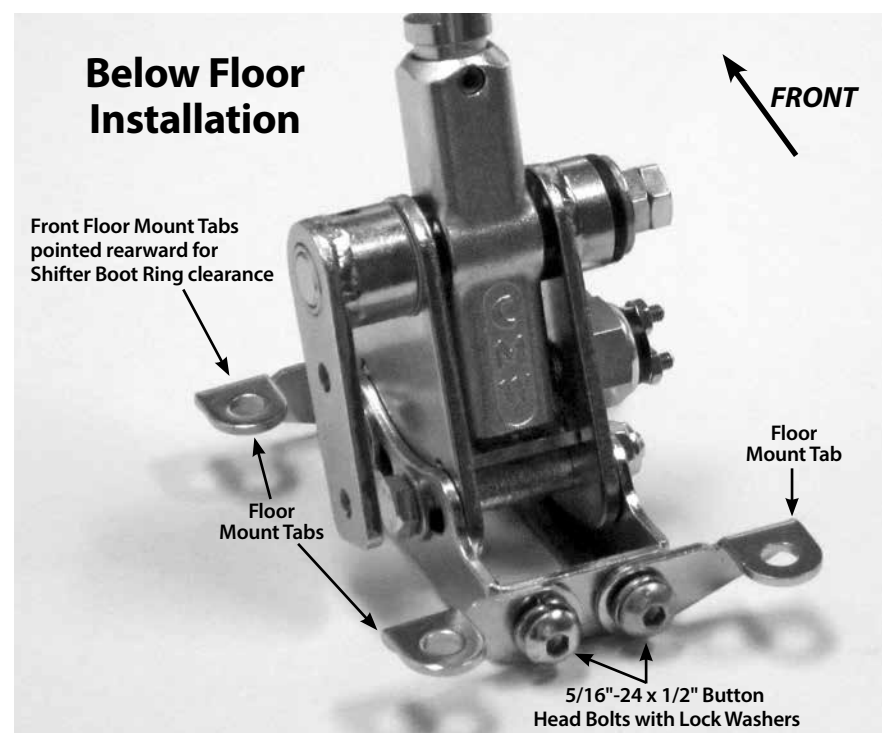
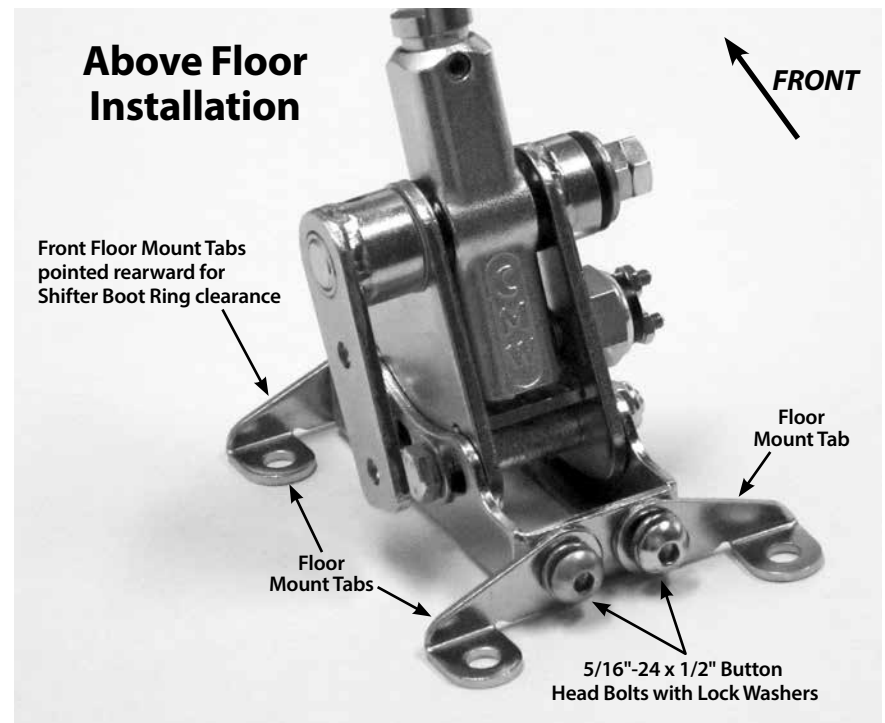

Fig. 2

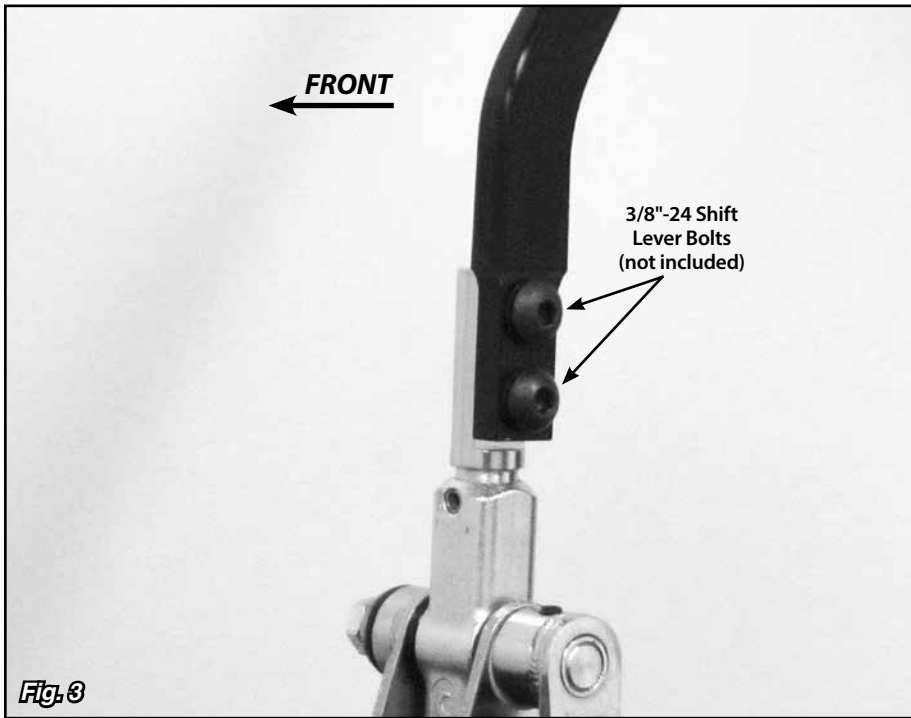

Fig. 3

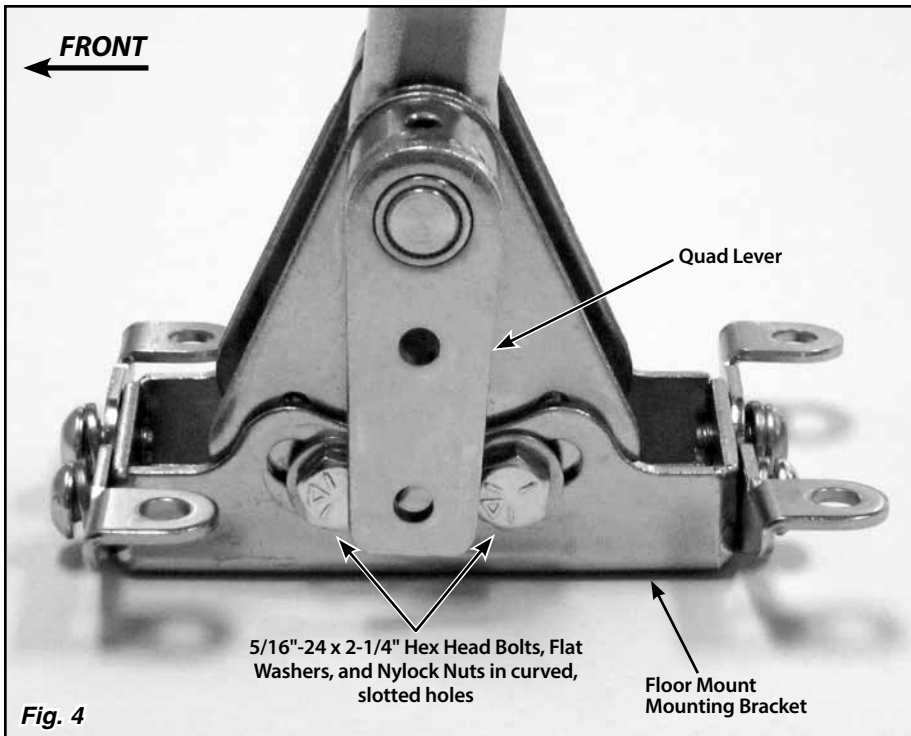

Fig. 4

Step 10: The threaded rod will connect the quad arm to the trans arm. Check to make sure that nothing will interfere with the travel of the threaded rod.

If there is any interference, the threaded rod can be bent slightly as needed.

Verify that both the Shifter and the transmission are in the Park position. Measure center-to-center between the 1/4" holes in the trans arm on the transmission and the quad arm on the Shifter. Subtract 1-3/4". **Fig. 7** This is the length you will cut the threaded rod to. Use a hacksaw or cutoff wheel to shorten the threaded rod. Then, de-burr the cut end of the rod.

Step 11: Verify that both 1/4"-28 jam nuts are on the threaded rod, and install a rod end onto each end of the threaded rod. Position the rod ends on the inside or outside of the quad arm and trans arm so that the threaded rod is as straight as possible. Attach the threaded rod assembly to the inside or outside of the quad arm and trans arm using the 1/4"-28 x 1" button head bolts, flat washers, and nylock nuts as shown in **Fig. 8**. The button head bolts can be installed from either direction, but make sure the rod end is sandwiched between the flat washer and the trans arm or quad arm. **Fig. 9**

Step 12: Check the adjustment of the shifter linkage by placing the shifter lever all the way forward into the Park position.

While the Shifter is in the Park position, make sure the transmission is firmly in the "Park" detent, with no tension on the threaded rod. You can verify this by removing the 1/4"-28 x 1" button head bolt with nylock nut that attaches the rod end to the quad arm or trans arm at either end of the threaded rod. Make sure the hole in the rod end exactly aligns with the hole in the quad arm or trans arm. The bolt should pass freely through both holes at the same time without binding. Do not force the holes to line up.

If the holes are not aligned, screw the rod end in or out just enough to be able to slide the bolt in and out without putting tension on the threaded rod. Make sure that the quad arm and trans arm do not move during the adjustment procedure. Use this adjustment routine until the bolt will pass freely in and out of both the rod end and the quad arm or trans arm. Reinstall the 1/4"-28 nylock nut and the flat washer onto the bolt and tighten.

Once you have the shifter linkage adjusted correctly, tighten the jam nuts on the threaded rod.

Neutral Safety Switch Wiring

NOTE: The neutral safety switch will have one or more washers under it. The washer(s) are used to adjust the depth of the neutral safety switch for proper operation. If the neutral safety switch is ever removed for any reason, you **MUST** reinstall the same washer(s) with the neutral safety switch to maintain the adjustment. **Fig. 10**

The Shifter's neutral safety switch is a simple on/off, non-directional switch. The switch passes current (turns on) when the ball is pushed in. It does not pass current (turns off) when the ball is out at its at-rest position.

Step 13: Connect the neutral safety switch between your ignition switch and starter circuits. Check the wiring of your fuse panel:

- **If there are (2) connections for a neutral safety switch**, run a #12 (or heavier) stranded wire from these terminals in your fuse panel to the (2) terminals on the neutral safety switch. That completes the neutral safety switch wiring.
- **If your fuse panel does not have neutral safety switch connections**, locate the wire going from the ignition switch to the starter. If GM color codes are used, this wire will usually be purple. After locating the wire, disconnect it from the starter. It must be cut and routed from the ignition switch to one of the neutral safety switch terminals, and from the other neutral safety switch terminal to the same stud on the starter where the original wire was removed. If the wire must be lengthened, be sure to use wire that is at least the same size or larger than the original.

Step 14: Reconnect the negative battery cable and check operation. Make sure that the engine will not start in Reverse or any forward gear.

If it does, try adding a thin washer or shim (any material is OK, such as gasket material) under the neutral safety switch. If the engine will not start in Park or Neutral, remove one of the washers from underneath the neutral safety switch, and try it again. Tighten all brackets and bolts correctly and securely and there should be no movement or maladjustment. If you have any questions after following this procedure, please call Clayton Machine Works Technical Support.

