



QUALITY... PLAIN & SIMPLE®

## Chrysler 727, 904, and 518 Hi-Tech Kickdown Kit Installation Instructions

### General Installation Notes:

Please read these instructions completely before beginning the installation. If you have any questions, please call.

Before beginning the installation, disconnect the negative battery cable and use wheel chocks to block the vehicle's wheels.

Make sure the engine, transmission, body and frame are properly grounded. We recommend using anti-seize lubricant on all aluminum threads.

**NOTE:** This Lokar Kickdown Kit is designed to be installed with a Lokar Cable Mounting Bracket (not included, available separately). The cable housing and inner wire are designed to be cut-to-fit.

Refer to Figs. 1 and 2 for the component names.

**Step 1:** Remove the cable end stop, kickdown throttle body fitting, and kickdown cable adjuster from the end of the inner wire. If you have the braided stainless steel housing, make sure you **DO NOT remove the ferrule from the cable housing**. Leave the kickdown mounting bracket on the kickdown cable adjuster. Remove the inner wire from the cable housing, and remove the transmission cable end assembly from the inner wire.

**Step 2:** Remove the lower left tail housing bolt from the transmission. Install the trans cable bracket and the cable housing onto the tail housing bolt, and reinstall onto the transmission as shown in **Fig. 3**.

**Step 3:** Install the transmission cable end assembly onto the original factory kickdown lever (not included) on the transmission, with the flat washer on top and the 1/4"-28 nylock jam nut underneath. **Fig. 4**

**Step 4:** If the Throttle Cable has already been installed, disconnect the Throttle Cable from the throttle arm. If the engine already has a Cable Mounting Bracket installed, remove the throttle cable adjuster. Leave the Cable Mounting Bracket in place. If the engine does not have a Cable Mounting Bracket already installed, install one now, following the installation instructions that were provided with the Cable Mounting Bracket.

**Step 5:** The kickdown mounting bracket mounts onto the back side of the Cable Mounting Bracket. The throttle cable adjuster will pass through the top hole in both the new kickdown mounting bracket **AND** the Cable Mounting Bracket. Position the kickdown mounting bracket behind the Cable Mounting Bracket so that the 5/16" diameter holes at the top of both brackets are aligned, the small 3/16" diameter holes near the center of the two brackets are aligned, and the kickdown cable adjuster is offset towards the driver side of the vehicle.

# Chrysler 727, 904, and 518 Hi-Tech Kickdown Kit Installation Instructions

Building American Quality... With A Lifetime Warranty!®

TOLL FREE 1-877-469-7440 • tech@lokar.com • www.lokar.com

**Step 5: (Continued)** Attach the kickdown mounting bracket to the Cable Mounting Bracket using the supplied #8-32 x 1/2" button head bolt and nylock nut through the small 3/16" diameter center holes in both brackets, but do not tighten yet. Insert the throttle cable adjuster (with the rear nut still installed) from the rear through the top holes in both brackets. Position it so that the threaded part of the throttle cable adjuster is approximately centered in the Cable Mounting Bracket. Reinstall the front adjuster nut.

Tighten the throttle cable adjuster nuts, the button head bolt and nut, and the kickdown cable adjuster. **Fig. 5**

**Step 6:** Route the cable housing up to the kickdown cable adjuster. **Make sure that the inner wire is removed from the cable housing!** If the cable housing is braided stainless steel, slide the ferrule down the housing towards the transmission, away from the end that is being cut. **Fig. 6 DO NOT remove the ferrule from the braided stainless steel housing!** If the cable housing is black universal or Vintage Series, remove the ferrule.

Measure the distance between the kickdown cable adjuster and the trans cable bracket. Add 1" to the measurement and mark the cable housing at that length.

If the cable housing is braided stainless steel, wrap tape around the cable housing at your mark and use a cutoff wheel or fine-toothed hacksaw to cut the cable housing. If the Kickdown Cable housing is black universal or Vintage Series, cut the cable housing at your mark with heavy duty 8" diagonal cutting pliers or a hacksaw. Lokar recommends Klein brand Diagonal Cutting Pliers, # D2000-28 available at The Home Depot or through W.W. Graingers, Part # 4A838.

After cutting the cable housing, put the ferrule back in place at the end of the cable housing. Insert the cable housing and ferrule into the kickdown cable adjuster.

**Step 7:** The tear drop (not included, comes with the Cable Mounting Bracket) will be attached to the throttle arm by the hex carb fitting. Separate the hex carb fitting from the kickdown throttle body fitting. Install the hex carb fitting and the tear drop onto the throttle arm as shown in **Fig. 7**. Hook the springs to the tear drop and tighten the nylock nut on the hex carb fitting. Then, back the nylock nut off just enough that the tear drop can pivot freely.

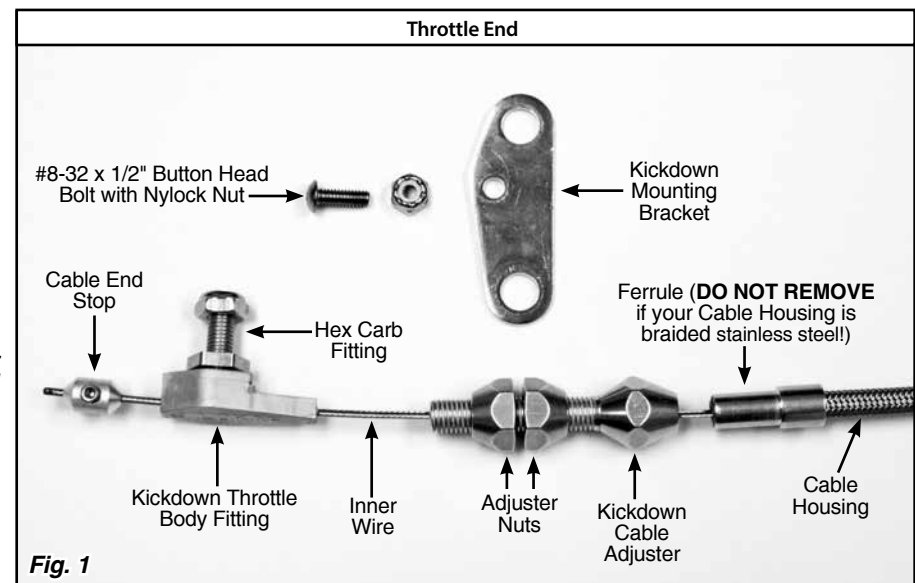


Fig. 1

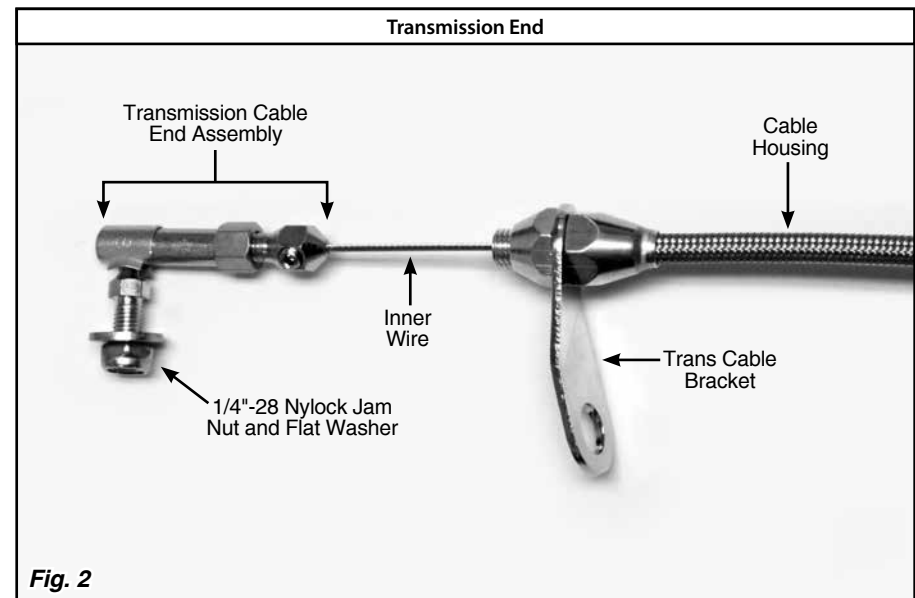


Fig. 2

# Chrysler 727, 904, and 518 Hi-Tech Kickdown Kit Installation Instructions

**Step 8:** Insert the inner wire all the way into the transmission cable end assembly and tighten the set screw using the provided 3/32" Allen wrench. Then, thread the inner wire up through the cable housing to the throttle.

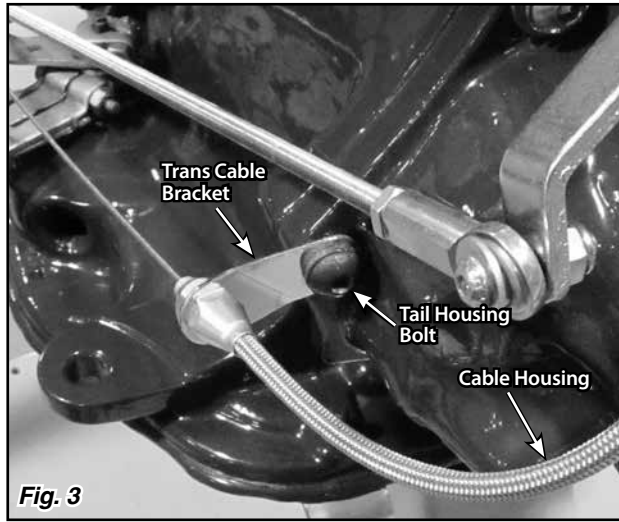
**Step 9:** Before connecting the Kickdown Cable to the throttle arm, install and adjust the throttle cable inner wire. Verify that the throttle plates are wide open while you have a helper hold the accelerator pedal to the floor. Once you are sure that the throttle cable is adjusted correctly, slide the kickdown throttle body fitting onto the kickdown cable inner wire, and connect the kickdown throttle body fitting to the hex carb fitting.

**Step 10:** This step will also be much easier with a helper. Slide the kickdown cable end stop onto the inner wire. Move the throttle to wide open and hold it there. With the throttle held wide open, pull the kickdown inner wire as tight as possible, making sure you get full travel out of the kickdown lever on the transmission. Slide the cable end stop up against the kickdown throttle body fitting and tighten the set screw using the supplied 5/64" Allen wrench. Release the throttle.

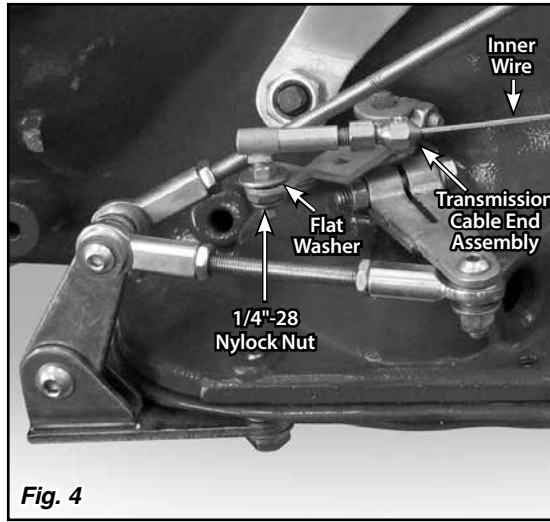
When the Kickdown Cable is properly adjusted you should be able to open the throttle to the wide open position without interference from the Kickdown Cable; and with the throttle wide open, you should not have any slack in the Kickdown Cable.

Double check to be sure that all throttle and kickdown linkage operates freely without binding. Test drive the vehicle. Once the Kickdown Cable is correctly adjusted and operating properly you can cut off the excess inner wire, leaving about 1/2" extending beyond the cable end stop to allow for future adjustment if needed.

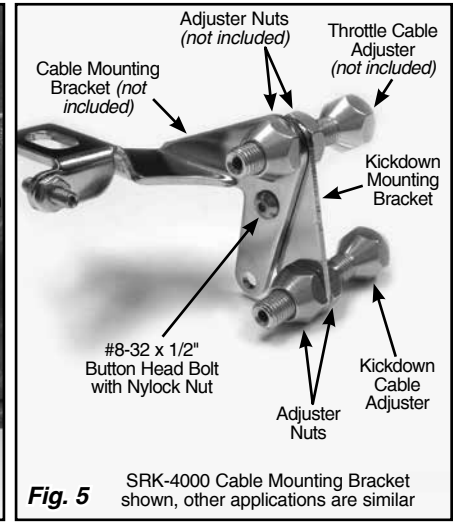
Final installation should look like **Fig. 7** and **Fig. 8**.



**Fig. 3**



**Fig. 4**



**Fig. 5**

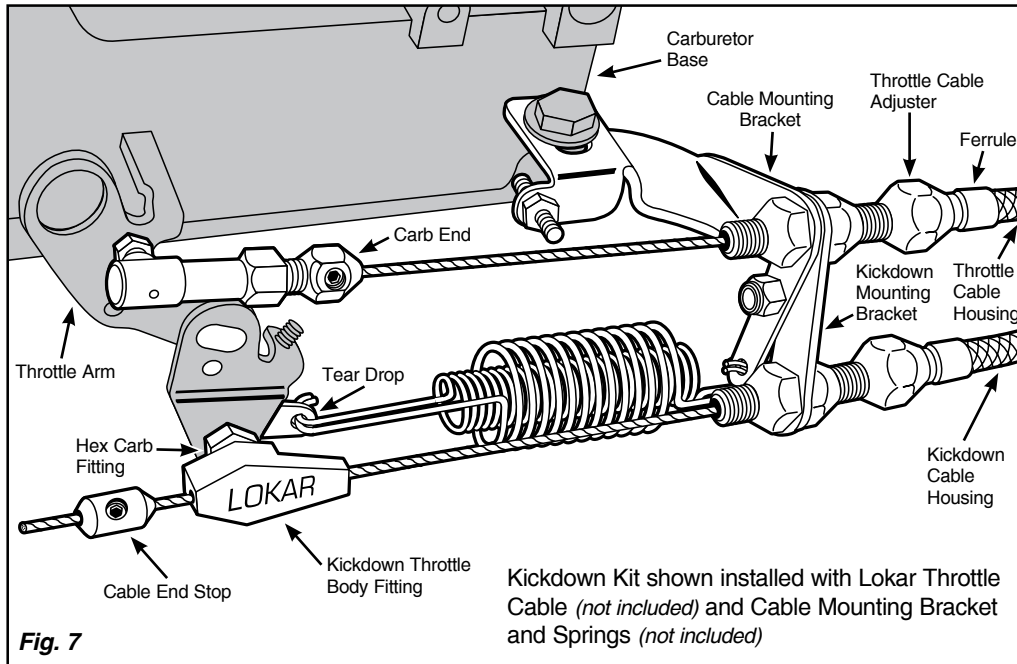
SRK-4000 Cable Mounting Bracket shown, other applications are similar

With the braided stainless steel Cable Housing, slide the Ferrule down the Housing past the cut line before cutting the Housing.

Inner Wire removed before cutting the Cable Housing

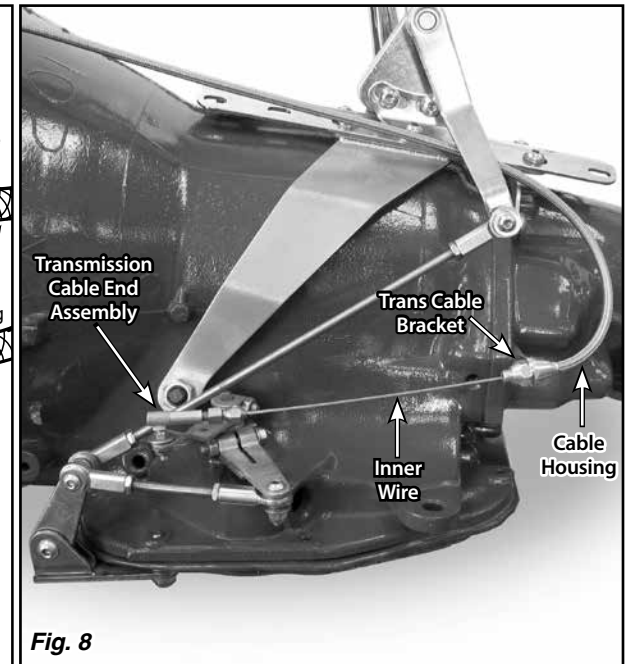


**Fig. 6**



**Fig. 7**

Kickdown Kit shown installed with Lokar Throttle Cable (not included) and Cable Mounting Bracket and Springs (not included)



**Fig. 8**