



QUALITY... PLAIN & SIMPLE®

GM Cable Operated Shifter Installation Instructions

General Installation Notes:

Please read these instructions completely before beginning the installation. If you have any questions, please call.

Before beginning the installation, disconnect the negative battery cable and use wheel chocks to block the vehicle's wheels.

Make sure the engine, transmission, body and frame are properly grounded.

All Lokar Installation Instructions can be found by visiting www.lokar.com/instructions.html.

Refer to Fig. 1 and Fig. 2 for the component names.

Tools and Materials Required:

- Standard Allen wrenches: 1/8", 5/32", 3/16"
- Wrench or Socket Sizes: 3/8", 7/16", 1/2", 9/16", 7/8", 15/16", 13mm (metric transmissions only)
- Tape Measure
- Metal cutting tool, such as a hacksaw or a die grinder with a cut-off wheel
- Drill and 5/16" drill bit
- Ohmmeter
- Wire cutters/strippers
- Wire crimping or soldering tools
- Blue thread locking compound

Lokar Shifters are designed to fit specific transmissions. Before installing the Shifter, verify you have the proper model for your transmission. If your Shifter does not seem to connect to the transmission properly, do not make modifications during installation as this may void your warranty. Call for assistance.

Verify the shifter length you have purchased is what you actually want. When installed, the bottom of the shifter lever will be approximately 3-1/2" - 4" above the bottom of the floor mount mounting bracket. From that point up to the top of the knob is how the shifter length is determined.

The Shifter must be installed into the vehicle before attempting to make any adjustments.

The shifter lever is designed to lock in Park and in Neutral. You must depress the release button in the top of the shifter knob in order to shift out of Park or Neutral.

To shift from Park directly to Drive (or Overdrive), depress the release button and hold it down while moving the shifter lever, and the shifter lever will stop in the Drive (or Overdrive) position. Once you release the button, the shifter lever can be moved into the next lower gear. You must depress the button to shift down again.

Step 1: If your vehicle already has a shifter of any type installed, disconnect all shifter linkage and remove the shifter and its related hardware (neutral safety switch, back-up light switch, etc.).

GM Cable Operated Shifter Installation Instructions

Building American Quality... With A Lifetime Warranty!®

TOLL FREE 1-877-469-7440 • tech@lokar.com • www.lokar.com

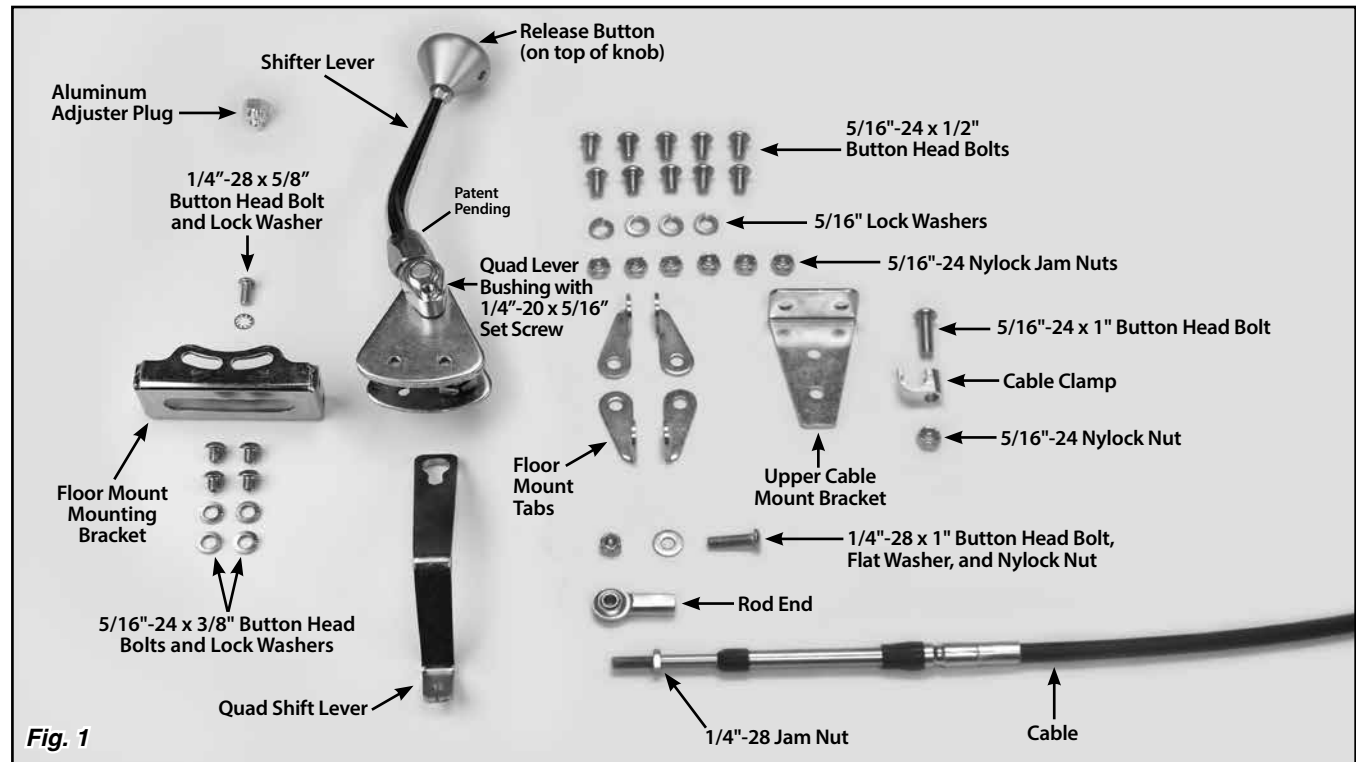

Fig. 1

Step 2: Take four 5/16" lock washers and the four 5/16"-24 x 3/8" button head bolts from the transmission shifter packet. **Make sure you are using 3/8" long bolts. They will be the shortest bolts in the packet.**

Place a lock washer on each of the bolts.

Position the shifter assembly into the floor mount mounting bracket as shown in Fig. 3. The floor mount mounting bracket can be installed in either direction (it does not have a front or a back). Install the 5/16"-24 x 3/8" button head bolts with lock washers through the curved, slotted holes and into the shifter assembly using a 3/16" Allen wrench. Fig. 3

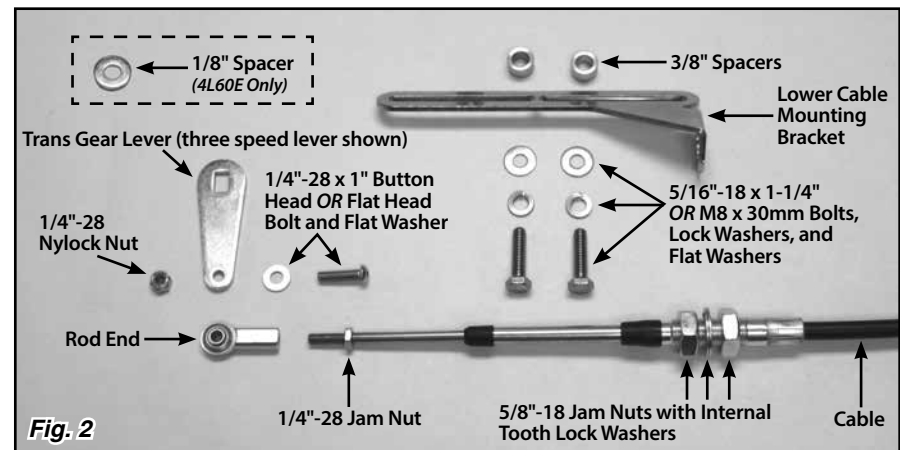

Fig. 2

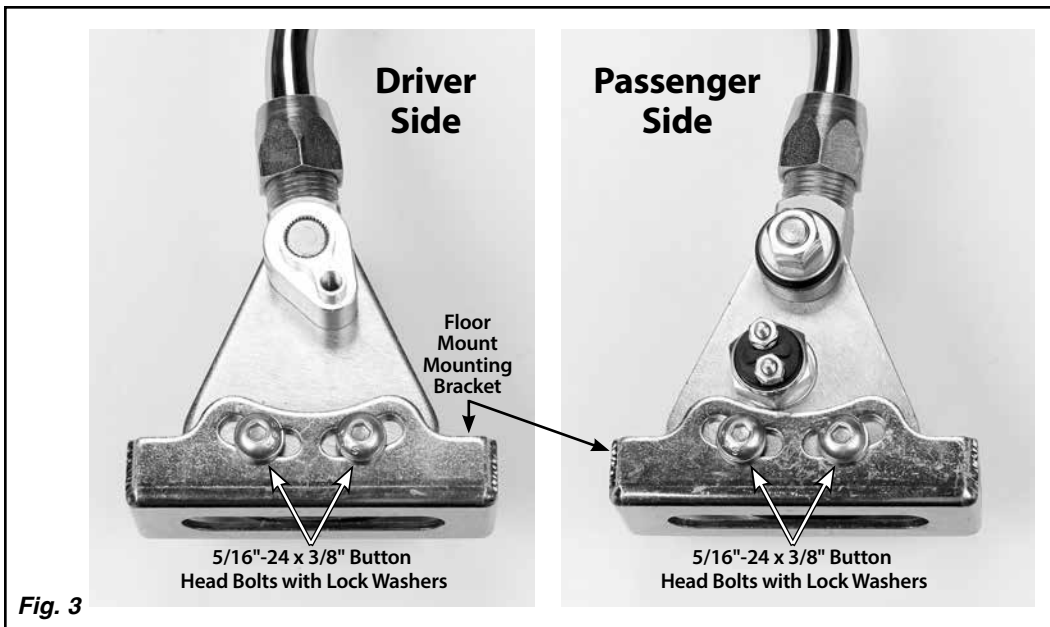

Fig. 3

Step 3: Determine exactly where you want the Shifter to be located. The Shifter may be mounted either on top of the floor or underneath the floor.

NOTE: For vehicles that had a floor shifter previously, determine if the existing hole(s) in the floor will be adequate for mounting and operation of the Lokar Shifter. If not, the floor will need to be modified.

If you are mounting the Shifter on top of the floor, you will need a slot in the floor for the quad shift lever to pass through. If you are mounting the Shifter underneath the floor, the opening will need to be large enough for the floor mount mounting bracket also.

NOTE: Round Lokar Shifter Boots and Boot Rings CANNOT be mounted directly on the floor with a Lokar Cable Operated Floor Mount Shifter.

The Shifter comes with a quad shift lever that has a 2-1/2" offset, which works the best in most installations. If the 2-1/2" offset will not work with your application, Lokar has quad shift levers available in both straight and 1-1/4" offset configurations. The bottom end of the quad shift lever should be generally aligned with the trans gear lever on the transmission. It is not necessary that the quad shift lever be perfectly aligned with the trans gear lever. The rod ends allow for a certain amount of misalignment.

Step 4: There are two pairs of floor mount tabs in the Shifter Kit. Which pair goes where will depend on if you are mounting the Shifter above or below the floor. See Fig. 4 to determine how the floor mount tabs need to be positioned for your particular application.

The floor mount tabs on the rear of the Shifter must be installed with the ears pointing towards the rear of the vehicle. If you are using a rectangular Lokar Shifter Boot and Ring mounted directly to the floor, the floor mount tabs on the front of the Shifter must also be installed pointing towards the rear of the vehicle. If you are not using a rectangular Lokar Shifter Boot and Ring, you may install the front floor mount tabs facing either direction.

Attach the floor mount tabs to the floor mount mounting bracket as shown in Fig. 4 with the 5/16"-24 x 1/2" button head bolts and lock washers. Leave the bolts loose enough so adjustments can be made later during the installation.

Step 5: Make sure the two 5/16"-24 x 3/8" button head bolts and lock washers in the curved, slotted holes in the driver side of the floor mount mounting bracket are tight using a 3/16" Allen wrench. Place the Shifter in the desired location on the vehicle's floor. Make sure the shifter lever will not interfere with the dash when in Park, or with the seat when in low gear. The shifter assembly may be tilted forward or backward if needed by loosening the two 5/16"-24 x 3/8" button head bolts and lock washers in the curved, slotted holes in the driver side of the floor mount mounting bracket. Retighten the button head bolts and lock washers in the curved, slotted holes once you have the shifter assembly at the angle you want. Fig. 5

If you ever disassemble the shifter assembly, be sure the 5/16"-24 x 3/8" button head bolts and lock washers are put back into the curved, slotted holes in the floor mount mounting bracket. **Installing longer bolts will prevent the Shifter from operating.**

NOTE: After installation, if you find the shape or length of the shifter lever is not suitable for your application, Lokar has a number of different styles and lengths of Shifter Lever Replacement Kits available for purchase separately through our dealer network.

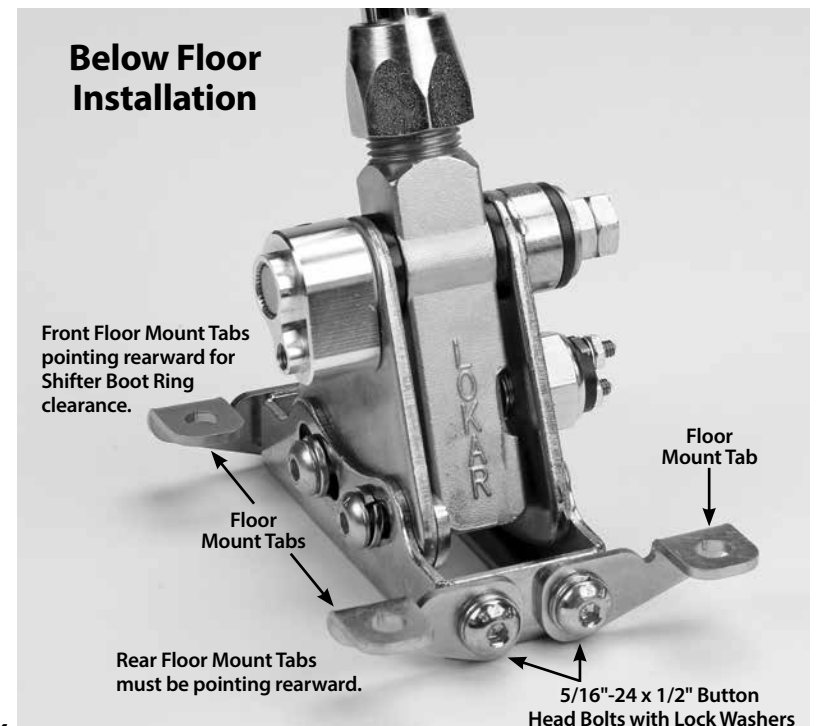
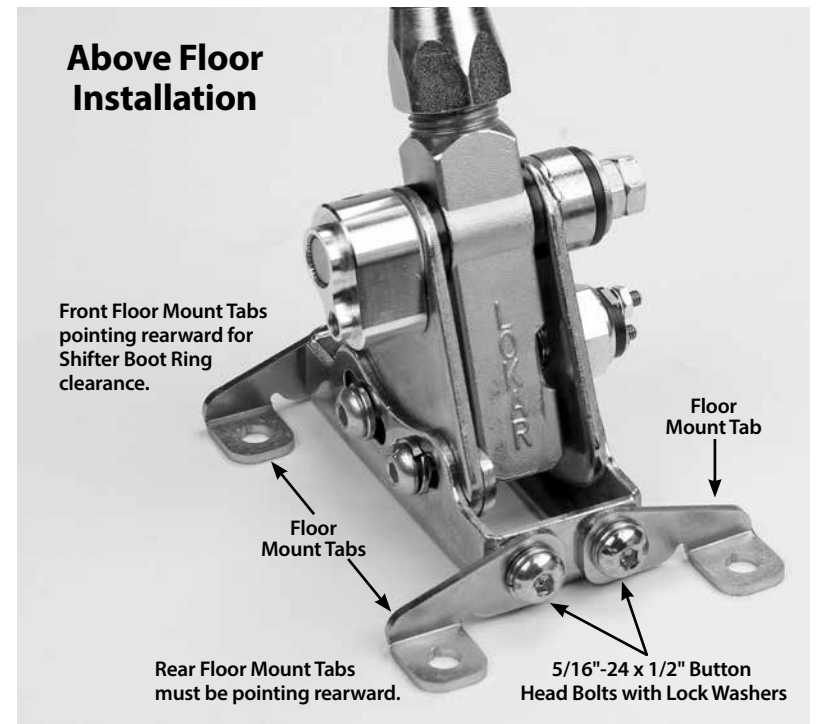
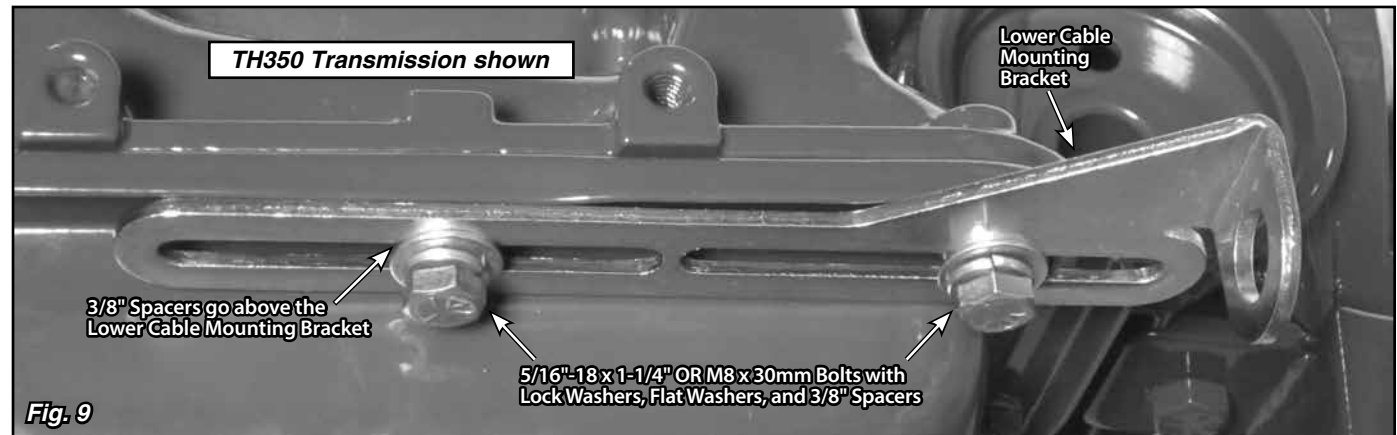
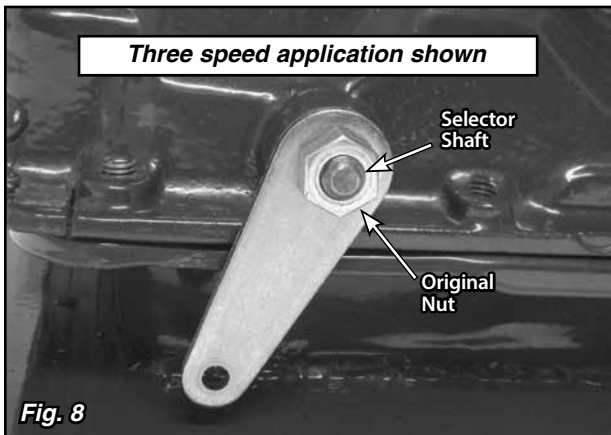
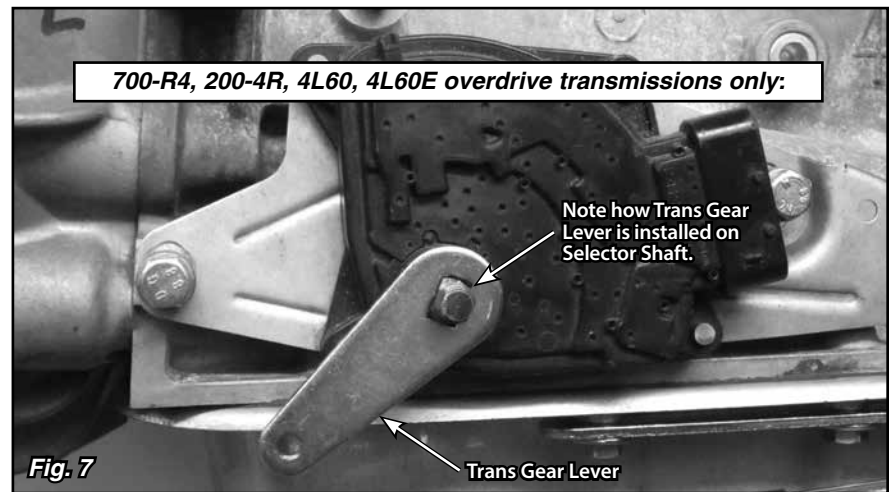
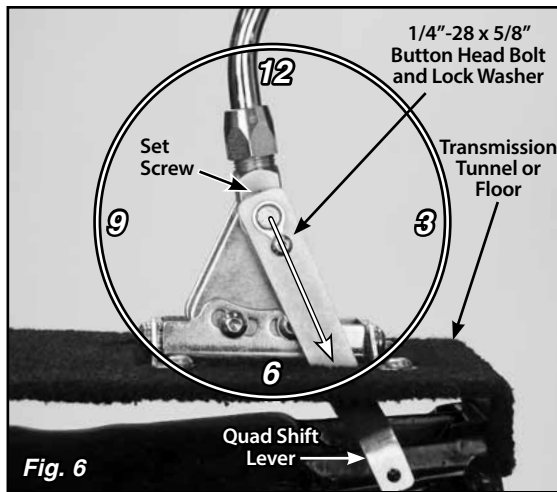
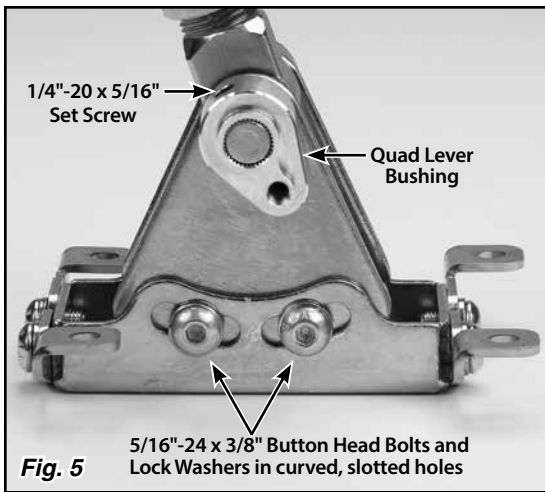

Fig. 4



Step 6: Determine the size and location of any opening(s) that need to be cut in the floor in order to mount the shifter assembly and allow full travel of the quad shift lever. Move the shifter lever through its full range of motion, in order to help determine where the cuts need to be made.

Cut those openings now.

Step 7: Place the shifter assembly in position on the vehicle. Push the floor mount tabs flush against the floor, and mark the center of the bolt holes in the floor mount tabs onto the floor. Center punch the marks, and drill four 5/16" diameter holes.

Step 8: Attach the floor mount tabs to the floor using four 5/16"-24 x 1/2" button head bolts and nylock jam nuts. Once the shifter assembly is mounted to the floor, tighten the floor mount tab to floor mounting bracket bolts using a 3/16" Allen wrench.

Step 9: Make sure the shifter lever is in the Park position. Temporarily place the quad shift lever in position on the quad lever bushing as shown in Fig. 6. Check for interference with the driver side rear floor mount tab or the vehicle floor. With the shifter lever in Park, you want the quad shift lever to be as close to the 4:30 - 5:00 position as the floor mount tab will allow, without the quad shift lever touching the floor mount tab or floor.

If the quad shift lever is not pointing towards the 4:30 - 5:00 position, loosen the set screw in the top of the quad lever bushing using a 1/8" Allen wrench. Slide the quad lever bushing off of the shifter. Reinstall the bushing pointing towards approximately the 4:30 - 5:00 position as shown. Retighten the set screw.

With the quad shift lever in position on the quad lever bushing, install the 1/4"-28 x 5/8" button head bolt and lock washer into the bushing, and tighten with a 5/32" Allen wrench. Fig. 6

Step 10: Make sure the transmission is in Park by rotating the original trans gear lever clockwise as far as it will go. Remove the original nut and trans gear lever from the transmission selector shaft. Install the new trans gear lever onto the selector shaft, pointing down and towards the front.

NOTE: 700-R4, 200-4R, 4L60, and 4L60E trans gear levers must be installed so the trans gear lever is in the furthest forward position. Fig. 7 This is so the cable will have full travel. The bolt hole in the trans gear lever on the 700-R4, 200-4R, and 4L60 transmissions is chamfered on one side. The chamfered side must face towards the transmission. This is required for clearance from the oil pan when the transmission is in low and second gears.

Secure the new trans gear lever with your original nut. Fig. 8

Step 11: Install the lower cable mounting bracket on the driver side of the transmission pan, using the provided longer bolts, lock washers, flat washers, and 3/8" spacers. Do not tighten the bolts yet. Most TH350 and TH400 transmissions use standard thread bolts (5/16"-18 x 1-1/4"). 700-R4, 200-4R, 4L60, and 4L60E transmissions use metric bolts (M8 x 30mm). The TH350 uses the two rearmost pan bolts on the driver side, and TH400, 700-R4, 200-4R, 4L60, and 4L60E use the two pan bolts directly behind the selector shaft. Fig. 9

Step 12: Make sure the shifter lever and the transmission are both in the Park position. Remove the first 5/8"-18 jam nut (15/16" wrench size) and one of the internal tooth lock washers from the cable. Install the cable into the lower cable mounting bracket, and then reinstall the lock washer and jam nut onto the cable.

Step 13: Make sure the 1/4"-28 jam nuts are installed on each end of the cable. Then, install the rod ends onto the cable, threading them on approximately halfway. Do not tighten the jam nuts against the rod ends yet.

Step 14: The inner cable needs to be fully extended all the way out at the transmission end when it is attached to the trans gear lever. Pull the inner cable out as far as it will go. Adjust the position of the lower cable mounting bracket, the position of the cable itself in the bracket, and/or the rod end so the hole in the rod end lines up with the hole in the trans gear lever with the inner cable fully extended and the transmission in Park. Attach the rod end at the transmission to the trans gear lever:

- **TH350 and TH400** transmissions use a 1/4"-28 x 1" button head bolt, flat washer, and nylock nut. The rod end attaches to the outside of the trans gear lever, away from the transmission. The button head bolt can be installed from either direction, but make sure the rod end is sandwiched between the flat washer and the trans gear lever. **Fig. 10 & 11**

- **700-R4, 200-4R, and 4L60** transmissions use a 1/4"-28 x 1" flat head bolt, flat washer, and nylock nut. The flat head bolt is installed from the inside of the trans gear lever, and the rod end attaches to the outside of the trans gear lever, away from the transmission. Make sure the rod end is sandwiched between the flat washer and the trans gear lever. **Fig. 10 & 12**

- **4L60E** transmissions use a 1/4"-28 x 1" button head bolt, a 1/8" spacer, a flat washer, and a nylock nut. The rod end attaches to the inside of the trans gear lever, towards the transmission. The 1/8" spacer goes between the rod end and the trans gear lever. The button head bolt can be installed from either direction, but make sure the rod end is sandwiched between the flat washer and the spacer. **Fig. 10 & 13**

Once the rod end is attached to the trans gear lever, tighten the lower cable mounting bracket bolts.

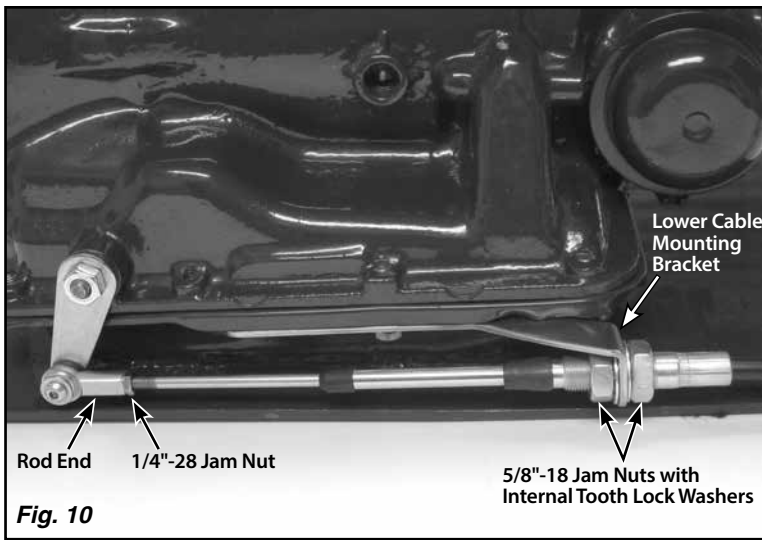

Fig. 10

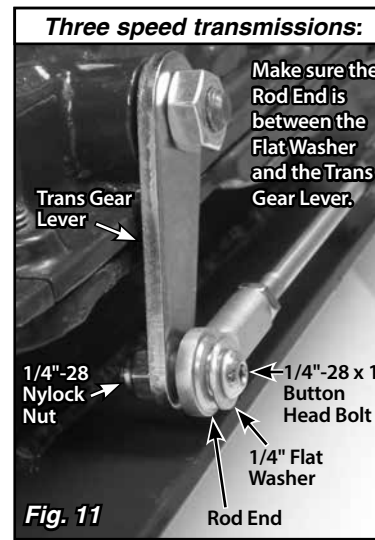

Fig. 11

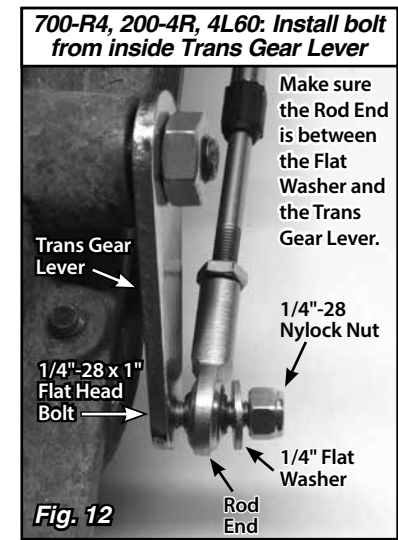

Fig. 12

4L60E Only: Rod End goes on inside of Trans Gear Lever

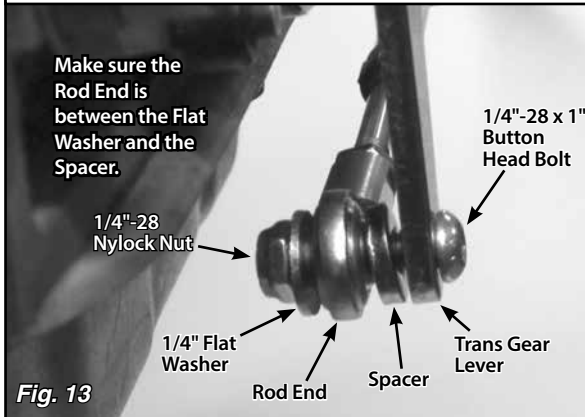

Fig. 13

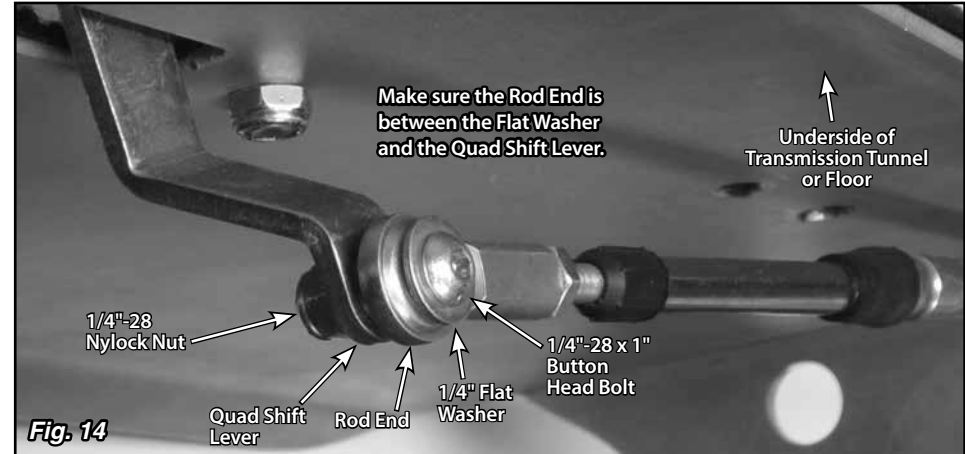

Fig. 14

Step 15: Route the cable up to the Shifter and attach the other rod end to the quad shift lever using a 1/4"-28 x 1" button head bolt, flat washer, and nylock nut. **Fig. 14** The button head bolt can be installed from either direction, but make sure the rod end is sandwiched between the quad shift lever and the flat washer. When routing the cable, make sure it is not touching the exhaust or any moving parts. The cable should be routed as smoothly as possible without any sharp bends.

Step 16: Position the upper cable mounting bracket up against the bottom of the floor and next to the cable, aligned with the retaining groove on the cable. Align the upper cable mounting bracket with the quad shift lever, where the cable can push and pull in a smooth motion.

NOTE: The location of the upper cable mounting bracket is an important factor in how smoothly the Shifter operates, so make sure it is aligned correctly.

Determine how the cable clamp should be oriented on the upper cable mounting bracket and which bolt hole should be used for the best alignment with the quad shift lever. The cable clamp can be installed with the bolt above or below the cable. Insert the 5/16"-24 x 1" button head bolt into the cable clamp, and position the cable clamp on the cable, making sure the bolt is seated in the retaining groove. **Fig. 15**

Install the cable clamp and 5/16"-24 x 1" button head bolt on to the upper cable mounting bracket and secure with a nylock nut. **Fig. 16**

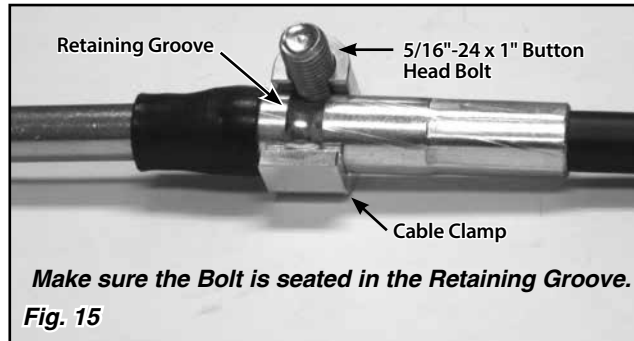

Fig. 15

Step 17: Make sure the location chosen for the cable clamp on the upper cable mounting bracket will allow the cable to go straight to the hole in the quad shift lever without binding in any direction. Before drilling the bolt holes in the floor, be sure everything is mocked up correctly and if possible, clamp the upper cable mounting bracket in place and check operation of the Shifter.

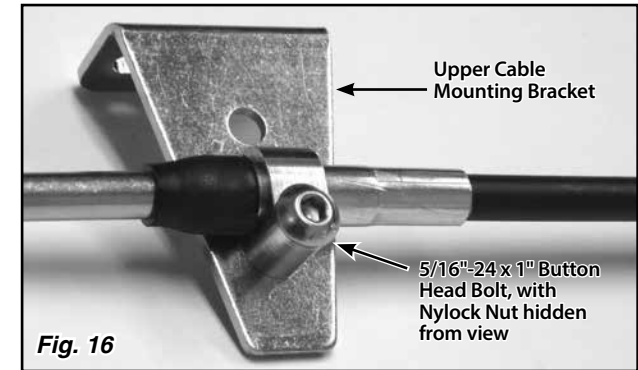

Fig. 16

Mark the center of the holes, center punch the marks, and drill both holes using a 5/16" drill bit.

Step 18: Install the upper cable mounting bracket on the floor using the 5/16"-24 x 1/2" button head bolts and nylock jam nuts. **Fig. 17**

Step 19: Check the adjustment of the shifter cable by placing the shifter lever all the way forward into the Park position. Make sure the release button still moves up and down freely. The release button should be flush with the knob in Park and Neutral. In the Reverse position, you cannot pull the lever back into Neutral without depressing the release button.

While the shifter lever is in the Park position, make sure the transmission is firmly in the Park detent, with no tension on the cable. You can verify there is no tension on the cable by removing the 1/4"-28 x 1" bolt with nylock nut that attaches the rod end to the quad shift lever or trans gear lever at either end of the cable. Make sure the hole in the rod end exactly aligns with the hole in the quad shift lever or trans gear lever. The bolt should pass freely through both holes at the same time without binding. Do not force the holes to line up.

If the holes are not aligned, use the 5/8"-18 jam nuts at the lower cable mounting bracket to get the adjustment close. Then, you can fine-tune it by adjusting the rod ends until you can slide the bolt in and out without putting tension on the cable. Make sure the quad shift lever and trans gear lever do not move during the adjustment procedure. Also, make sure the inner cable is still fully extended at the transmission end.

Use this adjustment routine until the bolts will pass freely in and out of both of the rod ends and the quad shift lever and trans gear lever. Reinstall the 1/4"-28 nylock nuts and the flat washers onto the bolts and tighten.

Once you have the shifter cable adjusted correctly, tighten the 1/4"-28 jam nuts on the ends of the cable, and the 5/8"-18 jam nuts at the lower cable mounting bracket.

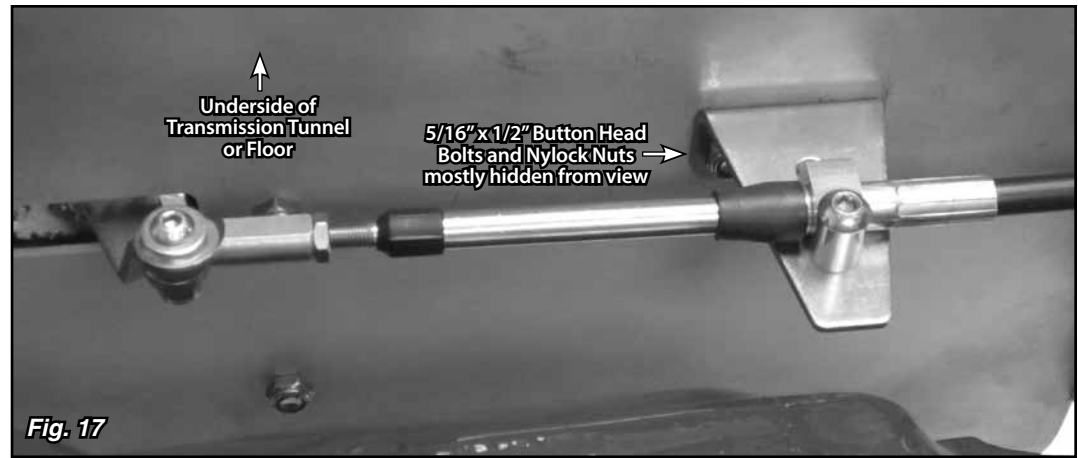

Fig. 17

Neutral Safety Switch Adjustment and Wiring

Step 20: For the neutral safety switch to function properly, the shifter linkage must be adjusted correctly. Do not attempt to adjust the neutral safety switch unless you have completed **Step 19**.

The Lokar Neutral Safety Switch is a simple on/off, non-directional switch. The switch passes current (turns on) when the ball is pushed in. It does not pass current (turns off) when the ball is out at its at-rest position.

Double check to make sure the bolts in the curved, slotted holes in the **driver** side of the floor mount mounting bracket are tight.

Step 21: Remove the neutral safety switch and washer (**Fig. 18**) from the **passenger** side of the Shifter using a 7/8" wrench or socket.

Step 22: Loosen, but do not remove, the two 5/16"-24 x 3/8" button head bolts and lock washers that connect the passenger side of the floor mount mounting bracket to the switch plate (the bolts are in curved, slotted holes). **Fig. 18**

WARNING: Before taking the shifter lever out of Park, be sure the vehicle's tires are blocked and the parking brake is set to avoid movement of the vehicle.

Step 23: Put the shifter lever into the Reverse position. Reposition the switch plate so the hole in the switch plate lines up with the center groove in the shifter body. **Fig. 19** Screw the provided aluminum adjuster plug into the neutral safety switch opening. Wiggling the switch plate slightly forward and back while you are screwing the aluminum adjuster plug in will help get the shifter body centered on the adjuster plug. **Fig. 20**

Step 24: Retighten the two 5/16"-24 x 3/8" button head bolts and lock washers that attach the passenger side of the floor mount mounting bracket to the switch plate.

Step 25: Remove the aluminum adjuster plug, and reinstall the neutral safety switch and washer onto the Shifter. Test for continuity by connecting an ohmmeter lead to each stud on the neutral safety switch. When adjusted correctly, you will only have continuity between the two switch studs when the shifter lever is in Park or Neutral. Continuity in any other gear requires readjustment of the neutral safety switch or the shifter linkage.

Step 26: Connect the neutral safety switch between your ignition switch and starter circuits. Check the wiring of your fuse panel:

- **If there are (2) connections for a neutral safety switch**, route a #12 (or heavier) stranded wire from these terminals in your fuse panel to the (2) terminals on the neutral safety switch. That completes the Neutral Safety Switch wiring.
- **If your fuse panel does not have neutral safety switch connections**, locate the wire going from the ignition switch to the starter. If GM color codes are used, this wire will usually be purple. After locating the wire, disconnect it from the starter. It must be cut and routed from the ignition switch to one of the neutral safety switch terminals, and from the other neutral safety switch terminal to the same stud on the starter where the original wire was removed. If the wire must be lengthened, be sure to use wire at least the same size or larger than the original.

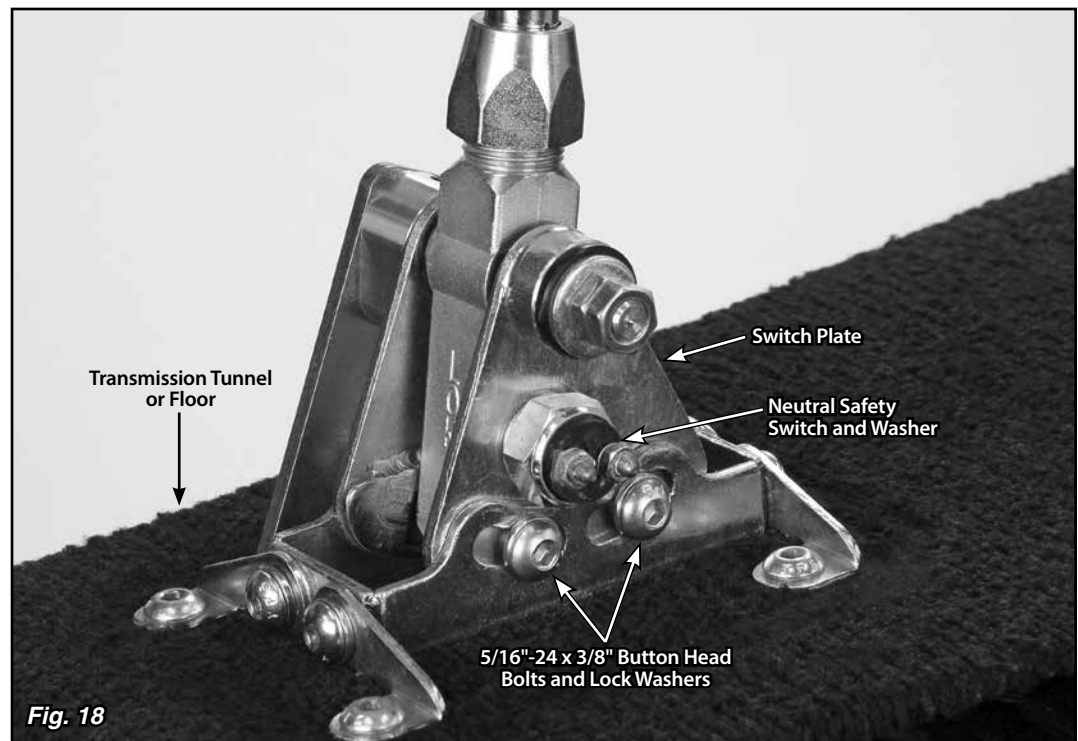
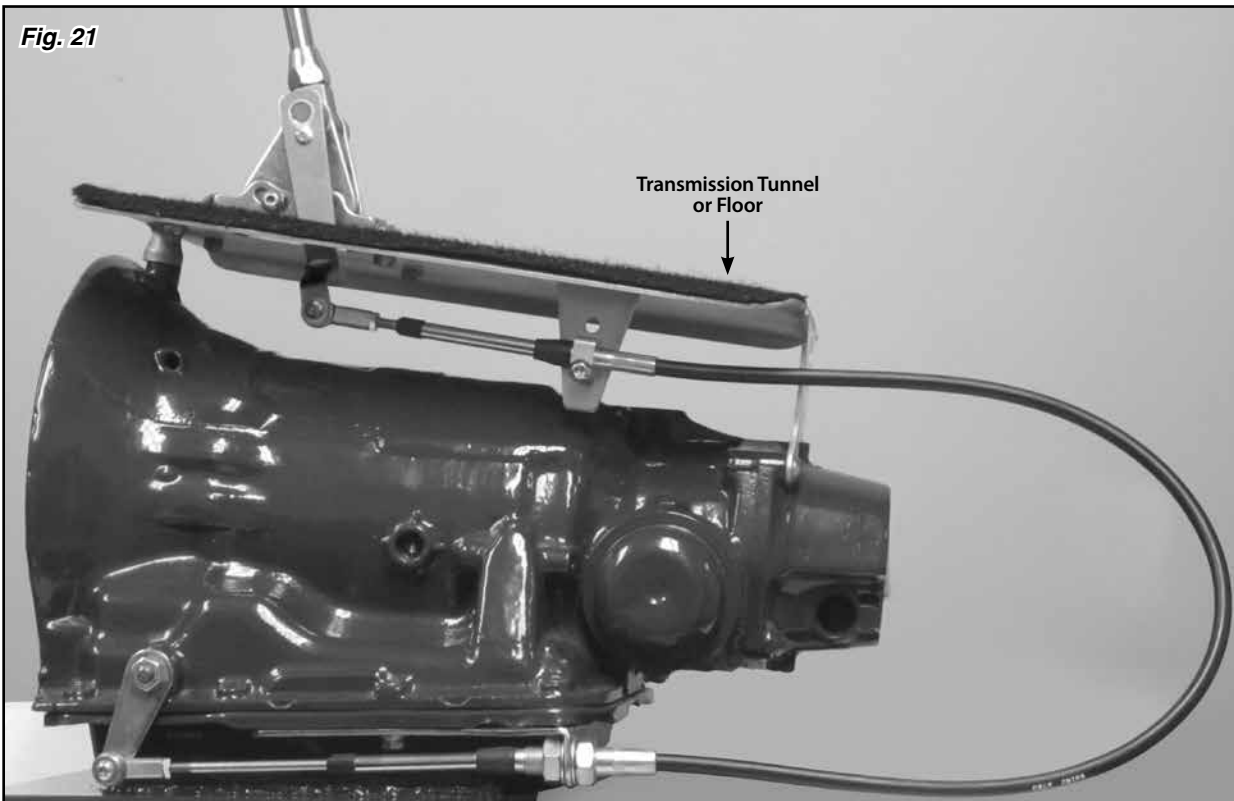
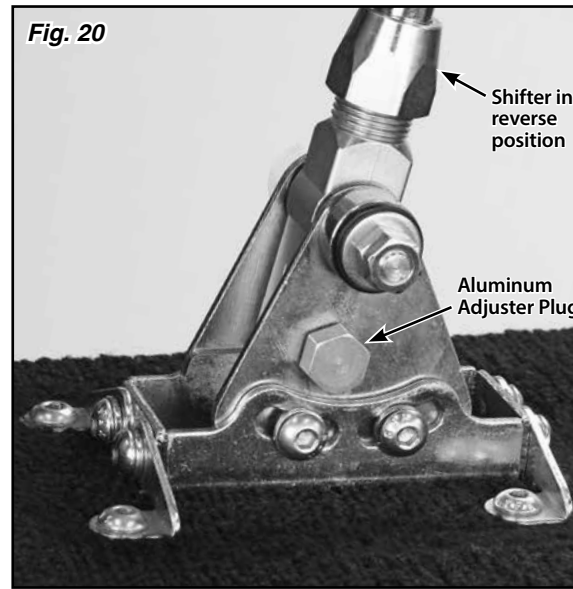
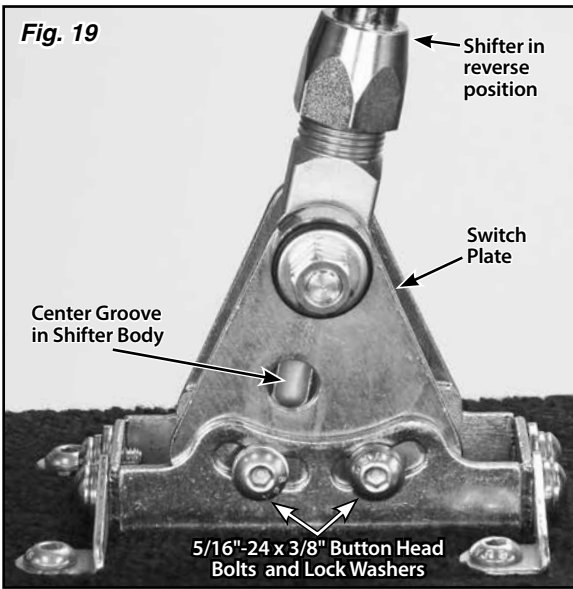

Fig. 18

Step 27: Reconnect the negative battery cable and check operation. Make sure the engine will not start in Reverse or a drive gear. If it does, follow the neutral safety switch adjustment procedure again. If your car should ever start in any gear other than Park or Neutral, readjust the neutral safety switch accordingly. Tighten all brackets and bolts correctly and securely and there should be no movement or maladjustment. If you have any questions after following this procedure, please call Lokar Technical Support.

Step 28: Once the installation is completely finished and the neutral safety switch is adjusted, remove each of the 5/16"-24 x 3/8" button head bolts and lock washers from the curved, slotted holes in the floor mount mounting bracket one at a time, apply blue thread locking compound to the threads, and reinstall.

Fig. 21 shows a completed installation.



Lokar Shifter Knob Removal Instructions (For Shifters Manufactured 1995 and Later)

For Shifters manufactured 1994 and earlier, please contact Lokar for assistance.

To Remove the Shifter Knob:

- Step 1:** Make sure the shifter lever is all the way forward in the Park position.
- Step 2:** Loosen the jam nut below the shifter knob. **DO NOT** loosen or remove the set screw in the knob. **Fig. 22**
- Step 3:** Turn the shifter knob counter-clockwise to remove.

To Install the Shifter Knob:

- Step 1:** Make sure the jam nut is still in place on the shifter lever.
- Step 2:** Screw the shifter knob onto the shifter lever until the release button comes up flush with the top of the shifter knob.
- Step 3:** Tighten the jam nut up against the bottom of the shifter knob.
- Step 4:** Check to make sure depressing the release button allows the shifter lever to be moved, and the shifter lever still locks in Park and Neutral. If the shifter lever will not come out of Park with the release button fully depressed, tighten the knob one turn and check it again. If the shifter lever does not lock in Park, loosen the knob one turn and check it again.

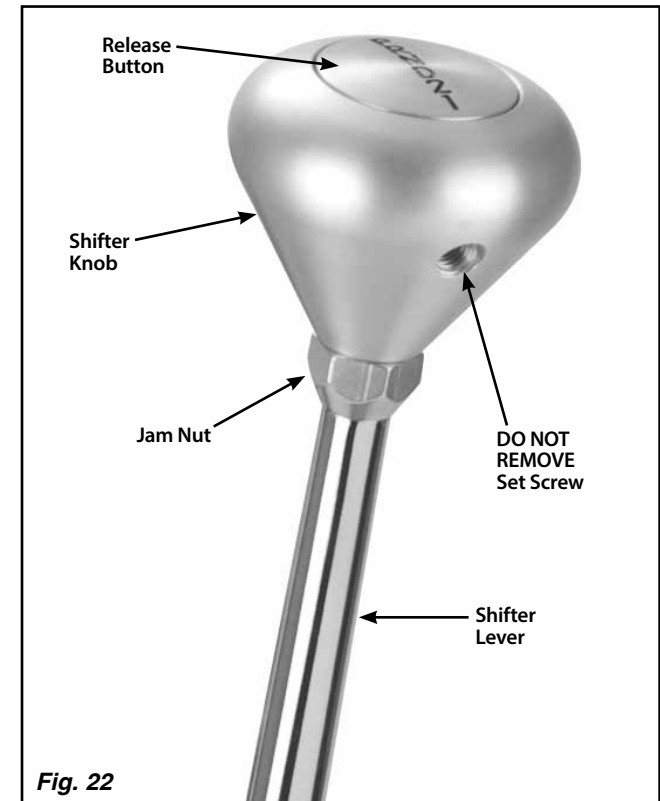

Fig. 22