



QUALITY... PLAIN & SIMPLE®

Direct Fit Brake & Clutch Pedal Arm Installation Instructions For Kugel 180 Degree Pedals

Direct Fit Brake & Clutch Pedal Arm Installation Instructions For Kugel 180 Degree Pedals

Building American Quality... With A Lifetime Warranty!®

TOLL FREE 1-877-469-7440 • tech@lokar.com • www.lokar.com

General Installation Notes:

Please read these instructions completely before beginning the installation. If you have any questions, please call.

Before beginning the installation, disconnect the negative battery cable and use wheel chocks to block the vehicle's wheels.

We recommend using anti-seize lubricant on all aluminum threads.

Kugel 180 Degree Brake Pedal Arm Installation

Refer to Fig. 1 for the part names.

Step 1: Disconnect the rod end on the master cylinder pushrod from the brake pedal arm. Remove the axle bolt from the pedal hanger bracket, and slide out the brake pedal axle and brake pedal arm together.

Step 2: Lubricate the brake pedal axle with a thin coat of lightweight oil and insert it into the bronze bushing that is pressed into the new Lokar Brake Pedal Arm. It must fit smoothly with no tight spots. If the axle does not fit through smoothly it may require some sanding of the axle or a slight hone of the bushing.

Step 3: On the driver side of the brake pedal arm, install one 31/32" Delrin® spacer onto the axle. On the passenger side of the brake pedal arm, install one 31/32" Delrin® spacer AND one 1-3/16" Delrin® spacer onto the axle. **Fig. 2** Slide the brake pedal assembly with the axle and spacers up into the pedal hanger bracket and reinstall the axle bolt, lock washer and nut. Make sure the brake pedal arm moves back and forth smoothly.

NOTE: If arranging the spacers as described above places the brake pedal too far to the driver side, the brake pedal can be shifted towards the passenger side by placing the 1-3/16" spacer on the driver side of the pedal arm instead.

Step 4: Attach the rod end to the brake pedal arm using the supplied 3/8"-24 x 1-3/4" bolt and nylock nut. Before tightening the nut, adjust the brake pedal arm to the desired height. This can be done by turning the rod end in or out. Tighten the nut after the adjustment is finished.

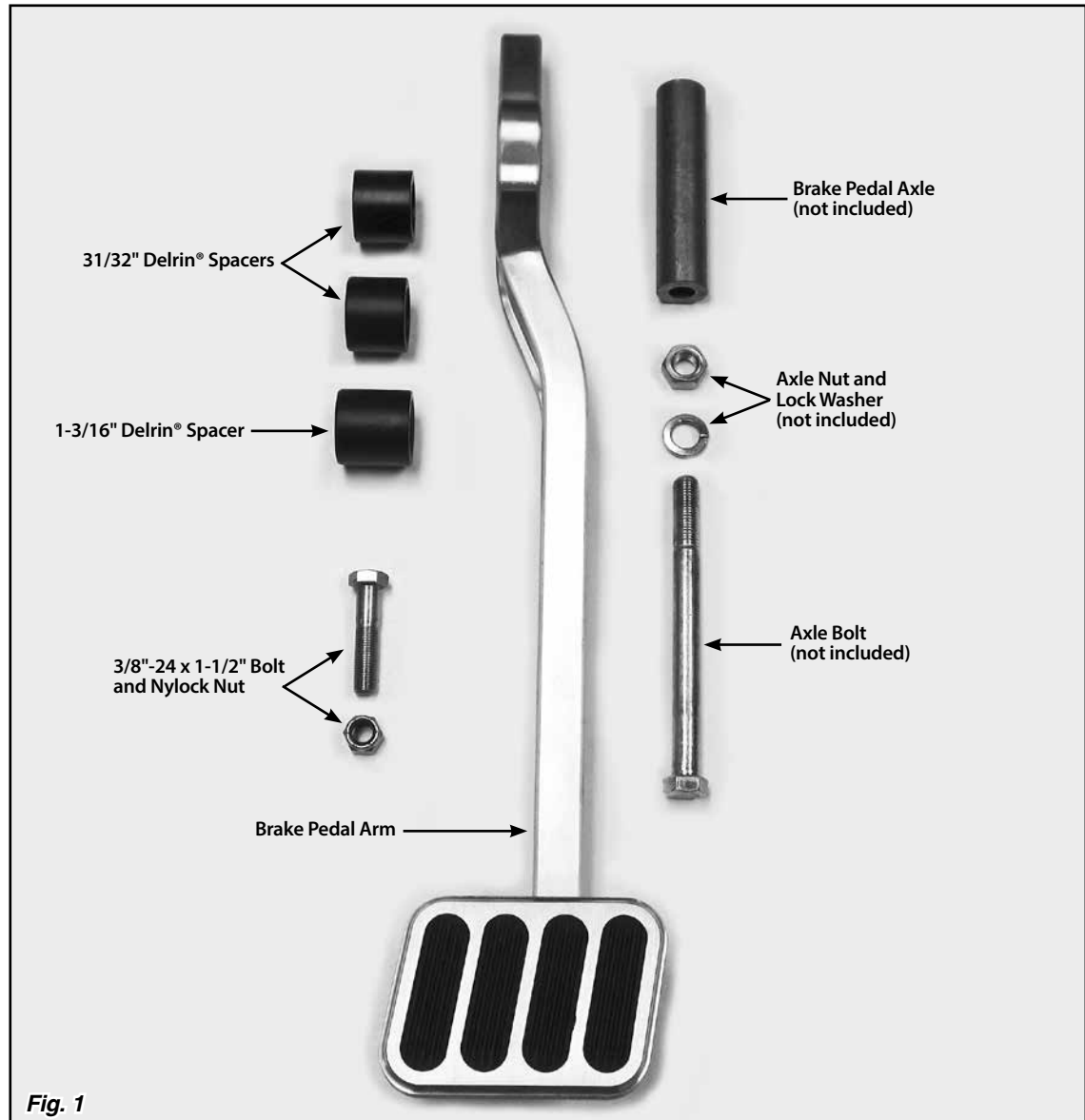
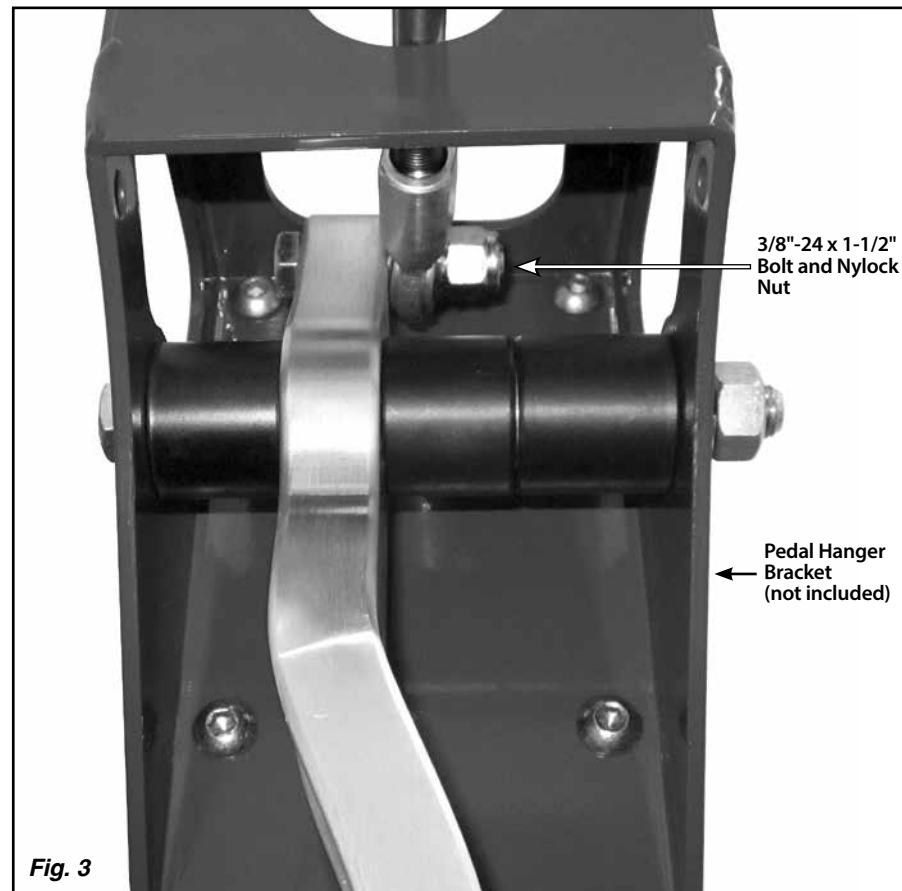
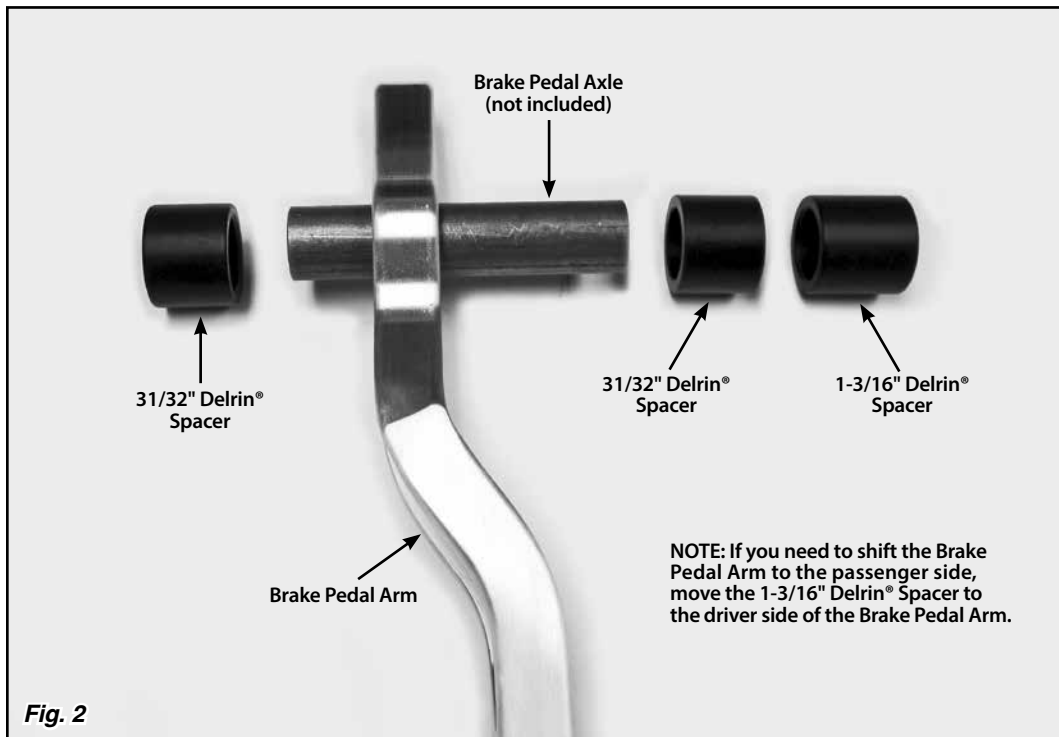

Fig. 1

Direct Fit Brake & Clutch Pedal Arm Installation Instructions For Kugel 180 Degree Pedals

Step 5: Adjust the brake light switch by loosening the two jam nuts on the switch. Turn the switch in or out as required. The brake light should turn on when the pedal is depressed approximately 1/2". Make sure the brake lights are not on with the brake pedal arm in the at-rest position.

The completed installation should look like **Fig. 3**.



Kugel 180 Degree Brake And Clutch Pedal Arm Installation

Refer to Fig. 1 and Fig. 4 for the part names. The Brake and Clutch Pedal Kit comes with all of the components that are included in the Brake Pedal Kit, plus the clutch pedal components shown in Fig. 4 (except the clutch pedal axle).

Step 1: Disconnect the rod ends on the pushrods from the existing brake and clutch pedal arms. Remove the axle bolt from the pedal hanger bracket. Slide out the clutch and brake pedal axles and pedal arms.

Step 2: Lubricate the axles with a thin coat of light weight oil and insert them into the bronze bushings that are pressed into the new Lokar Brake and Clutch Pedal Arms; they must fit smoothly with no tight spots. If either of the axles does not fit through smoothly, it may require some sanding of the axle or a slight hone of the bushing.

Step 3: On the brake pedal axle, install one 31/32" Delrin® spacer on the driver side of the brake pedal arm. Install one 31/32" Delrin® spacer AND one 1-3/16" Delrin® spacer on the passenger side of the brake pedal arm. **Fig. 2**

NOTE: If arranging the spacers as described above places the brake pedal too far to the driver side, the brake pedal can be shifted towards the passenger side by placing the 1-3/16" spacer on the driver side of the pedal arm instead.

Step 3 (continued):

On the clutch pedal axle, install the 7/8" Delrin® spacer on the driver side of the clutch pedal arm. Install the 5/16" Delrin® spacer on the passenger side of the clutch pedal arm. **Fig. 5**

NOTE: The clutch pedal position CANNOT be changed by switching the spacers around like the brake pedal can.

Slide the brake pedal assembly with the axle and spacers up into the pedal hanger bracket and reinstall the axle bolt just far enough to catch the center part of the pedal hanger bracket. Slide the clutch pedal assembly up into the pedal hanger bracket and push the axle bolt the rest of the way through. Install the axle lock washer and nut. Make sure the brake and clutch pedal arms move back and forth smoothly.

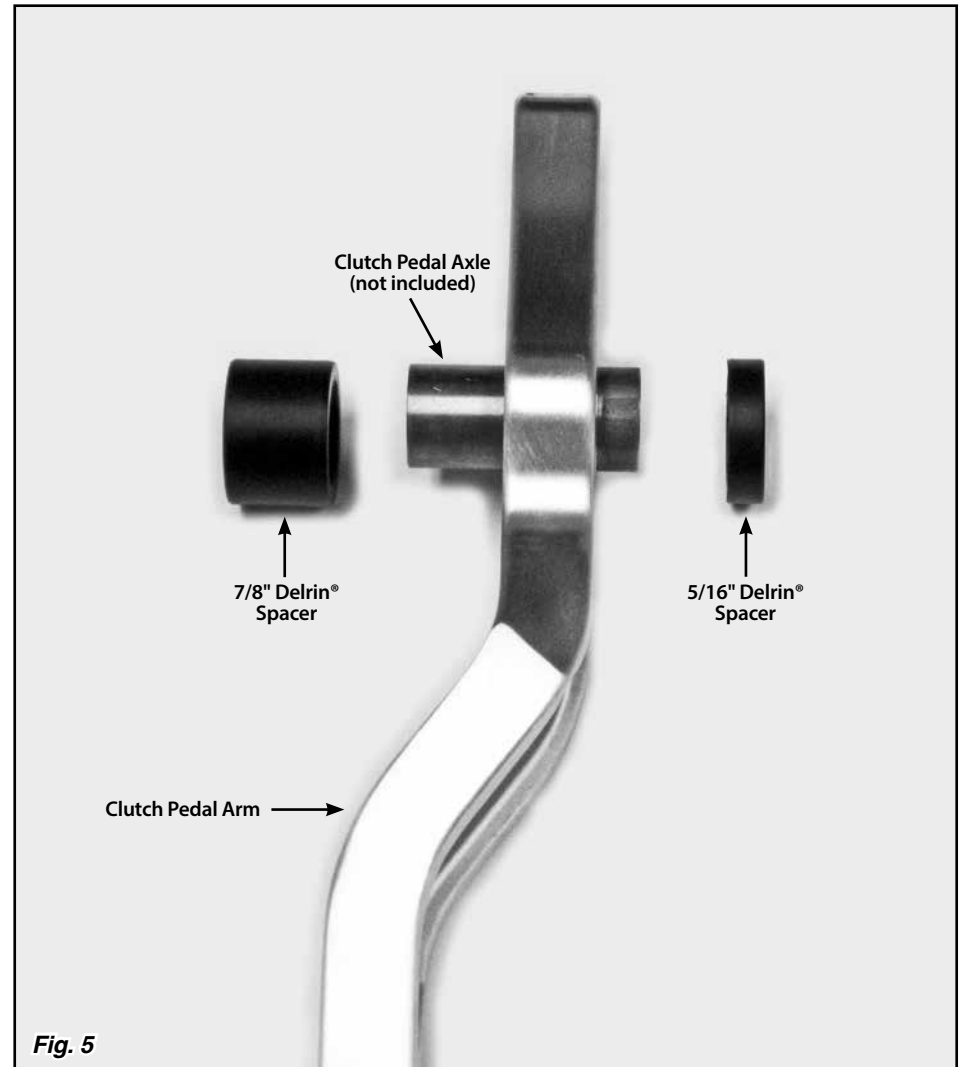
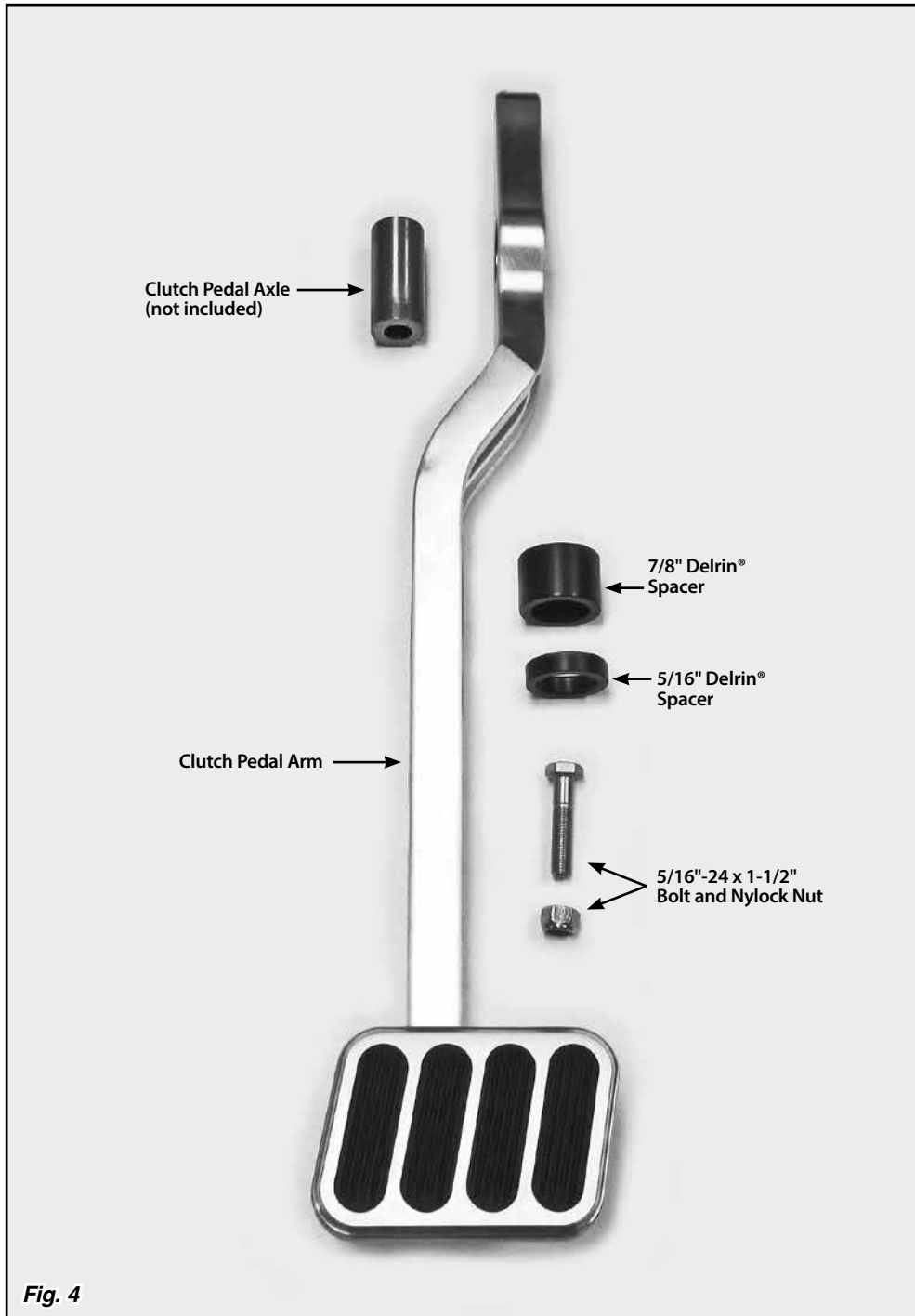

Direct Fit Brake & Clutch Pedal Arm Installation Instructions For Kugel 180 Degree Pedals

Step 4: Connect the rod ends to the brake and clutch pedal arms. The brake pedal arm uses the supplied 3/8"-24 x 1-3/4" bolt and nylock nut. The clutch pedal arm uses the supplied 5/16"-24 x 1-1/2" bolt and nylock nut. Before tightening the nuts, adjust the brake and clutch pedal arms to the desired height. This can be done by turning the rod ends in or out. Tighten the nuts after the adjustments are finished.

Step 5: Adjust the brake light switch (not included) by loosening the two jam nuts on the switch. Turn the switch in or out as required. The brake light should turn on when the pedal is depressed approximately 1/2". Make sure the brake lights are not on with the brake pedal arm in the at rest position.

The completed installation should look like **Fig. 6**.

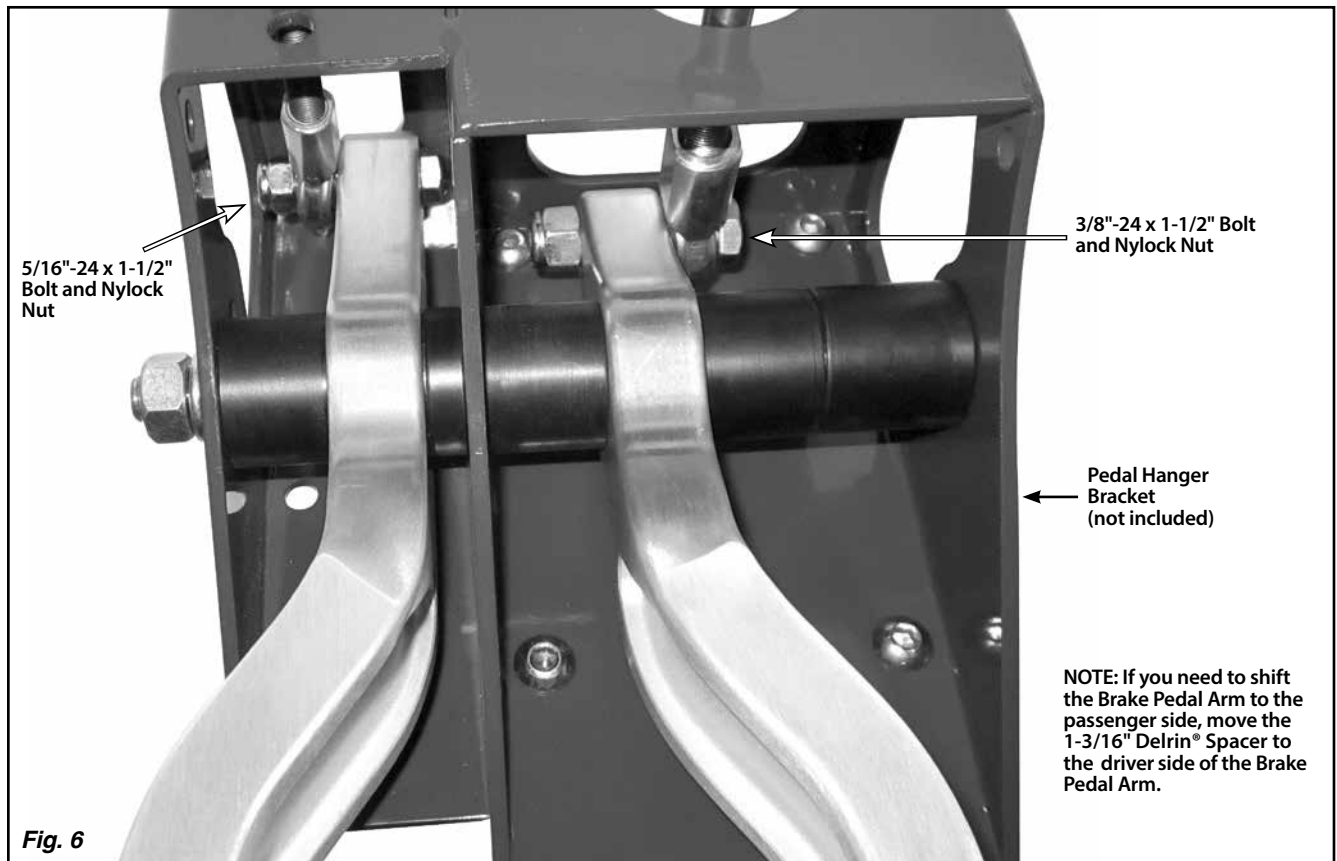

NOTE: Some styles of Lokar pedals have a reversible pedal pad that can be turned around to shift the position of the pad to the left or right. Each of these pedal pads will come with one of the rubber inserts not installed, and there will be a tube of instant adhesive in the kit.

If you have one of the styles with a reversible pedal pad and you would like to reverse it, simply remove the two flat head bolts from the pedal pad, rotate the pedal pad one half turn, and reinstall the flat head bolts. **Fig. 7**

Attach the rubber inserts to the aluminum pedal pad using the adhesive supplied in the kit.

Read the adhesive manufacturer's instructions for proper application. If excess adhesive gets on the aluminum pedal pad, clean it off with acetone before it dries. Apply a small amount of adhesive to the bottom of the recess in the aluminum pedal pad only. Install the rubber insert into the aluminum pedal pad, and apply pressure to the rubber insert for 60 seconds.

Instant Adhesive

Hazards Identification: Irritant. Irritating to eyes, skin, and respiratory system. Cyanoacrylate. Danger. Bonds skin and eyes in seconds.

Ingredients: Ethyl Cyanoacrylate

Symptoms of Exposure: Vapor irritating to eyes and respiratory system. Prolonged exposure may lead to non-allergic asthma.

First Aid Measures:
Ingestion: Ingestion not likely due to polymerization.
Inhalation: Remove to fresh air. If symptoms continue, seek medical advice.
Skin Contact: Soak in warm soapy water.
Eye Contact: Flush with water, seek medical attention.

KEEP OUT OF REACH OF CHILDREN

Additional Product Safety and Health Information Source:
Material Safety Data Sheet (MSDS RP, SI, FS, HT, & MG Series Cyanoacrylate Adhesive) or 1-800-255-3924

